

Powerco CPP – Portfolio Overview Document

| | |
|-----------------------------|--|
| Portfolio Name | Omokoroa/Aongatete/Katikati/Kauri Pt Reinforcement |
| Expenditure Class | Capex |
| Expenditure Category | Growth & Security |
| As at Date | 12 June 2017 |

| Expenditure Forecast ^{1,2} | Pre CPP | FY19 | FY20 | FY21 | FY22 | FY23 | Post CPP | CPP Period Total | Project Total |
|---|---------|-------|-------|-------|-------|-------|----------|------------------|---------------|
| Pre-Internal Cost Capitalisation and Efficiency Adjustments ³ (2016 Constant NZ\$(M)) | \$0.0 | \$1.2 | \$6.0 | \$3.4 | \$0.8 | \$0.0 | \$0.0 | \$11.4 | \$11.4 |
| Post-Internal Cost Capitalisation and Efficiency Adjustments (2016 Constant NZ\$(M)) | \$0.0 | \$1.3 | \$6.4 | \$3.6 | \$0.9 | \$0.0 | \$0.0 | \$12.3 | \$12.3 |

| Description | |
|------------------------------|--|
| Project need overview | The subtransmission network supplying the Omokoroa, Aongatete, Katikati and Kauri Point substations will not meet our security of supply standards in the near future due to capacity constraints of the existing circuits. Under fault conditions, the capacity of the subtransmission circuits are exceeded and subtransmission voltages drop below acceptable levels at Kauri Point and Katikati substations. |

| Preferred Solution | |
|----------------------------------|--|
| Project solution Overview | The preferred solution is to create a third circuit between Greerton and Omokoroa substations. This is done by creating a new 33kV underground circuit between Greerton and Bethlehem substations and reconfiguring the existing Greerton-Bethlehem circuit to create a third circuit between Greerton and Omokoroa. |

¹ Forecast expenditure is based on Powerco’s financial year (i.e. FY18 is for the period April 2017 through March 2018). Expenditures do not consider general price level changes over time (i.e. are in real or constant terms).

² Only includes Growth & Security Expenditure. Some projects discuss and rely on the replacement of assets that are at “end of life”. However, the replacement cost for these assets is accounted for in the Replacement Expenditure category.

³ All other forecast expenditure / cost estimates in this POD are pre-internal cost capitalisation and efficiency adjustments, consistent with this forecast.

| Need Identification | |
|---|--|
| Background | <p>The region to the northwest of Tauranga is supplied from four substations - Omokoroa, Aongotete, Katikati and Kauri Point, supplying a mix of urban and rural customers. The rural areas include small-holdings, market gardens, lifestyle blocks and kiwi fruit orchards. The urban areas in Omokoroa and Katikati are expected to experience significant growth due to subdivision expansion that has been identified in the Bay of Plenty’s (BoP) Smart-Growth strategy and Tauranga City Council City Plan⁴⁵ documents.</p> <p>The 2016 ADMD for the four substations is 24MVA. This is expected to grow to 30MVA by 2030.</p> <p>The four substations are connected by two 33kV sub-transmission circuits originating from the Greerton switching station as shown in Figure 1 and Figure 3. Two single circuit 33kV lines start from the Greerton 33kV switching station and run northwest to Omokoroa and on to Aongatete. From Aongatete two separate single 33kV circuits supply Katikati and Kauri Point respectively.</p> <p>During 2014 the Greerton-Omokoroa A and B overhead circuits were re-tensioned to operate at 70°C (originally designed to operate at 50°C).</p> |
| Underlying Drivers and Investment Triggers | <p>The following constraints/issues exist in this area:</p> <ul style="list-style-type: none"> • The combined ADMD peak demand of all four substations will exceed the (N-1) (OMO-GRE-A rated to 25MVA⁶) rating on the existing circuits between Greerton and Omokoroa by 2018/19. At this lower rating the supply network will not meet the requirements of Powerco’s Security-of-Supply Standard, which recommends that the combined load of the four substations should be afforded a (N-1), no break supply network with a security class of AAA. • There is some network interconnection at 11kV between the Tauranga planning area and the adjacent Waikino planning area (in the north). However, the transfer capacities are limited. • During outages of one of the Greerton-Omokoroa circuits (OMO-GRE-A & OMO-GRE-B) the 33kV delivery voltages to the Katikati and Kauri Pt substations are particularly low with the result that (for 2016 peak loads) the 33/11kV zone transformers will not be able to adequately regulate the 11kV bus voltages (i.e. maximum voltage tap positions are reached). • A 4km section of double circuit overhead 33kV line (circuits OMO-GRE-A and GRE-BTM) supplies both the Bethlehem and |

⁴ Tauranga City Council website

⁵ Operative District Plan 2012, Western Bay of Plenty District Council, <http://www.westernbay.govt.nz/>, retrieved 23 October, 2015.

⁶ The (N-1) rating of the Omokoroa 33kV circuits is 25MVA due to the voltage constraining effect of the smaller conductors on one of the circuits.



| | |
|---------------|---|
| | Omokoroa substations. It suffers from sympathetic tripping due to the fact that a fault current on one of the line circuits induces a current in the adjacent line circuit with the result that the existing protection trips the adjacent line. |
| Timing | The Omokoroa/Aongatete/Katikati/Kauri Pt network is currently constrained under certain contingent events. The network will exceed (N-1) security of supply by 2018/19. Given the complexity of the project Powerco intends to progress the preferred solution over four financial years, commencing FY2019, to alleviate any resource constraints. |

Demand Forecast | Tauranga Area

| TAURANGA AREA SUBSTATIONS | | | FORECAST MAXIMUM DEMAND [MVA] | | | | | | |
|---------------------------|----------------|-------------|-------------------------------|------|------|------|------|------|------|
| SUBSTATION | CLASS CAPACITY | GROWTH | 2016 | 2017 | 2018 | 2019 | 2020 | 2025 | 2030 |
| *Aongatete | 7.2 | 2.4% | 8.4 | 8.6 | 8.8 | 9.0 | 9.2 | 10.2 | 11.2 |
| Bethlehem | 8.0 | 3.9% | 9.4 | 9.8 | 10.1 | 10.5 | 10.9 | 12.7 | 14.6 |
| Hamilton St | 22.4 | 1.2% | 15.5 | 15.7 | 15.9 | 16.1 | 16.2 | 17.2 | 18.1 |
| *Katikati | 5.3 | 1.5% | 8.3 | 8.4 | 8.6 | 8.7 | 8.8 | 9.5 | 10.1 |
| *Kauri Pt | 2.0 | 0.6% | 3.1 | 3.1 | 3.1 | 3.2 | 3.2 | 3.3 | 3.4 |
| Matua | 7.2 | 0.3% | 10.2 | 10.2 | 10.2 | 10.3 | 10.3 | 10.5 | 10.6 |
| *Omokoroa | 13.2 | 1.3% | 11.5 | 11.6 | 11.8 | 11.9 | 12.1 | 12.8 | 13.6 |
| Otumoetai | 13.6 | 2.0% | 14.0 | 14.3 | 14.6 | 14.9 | 15.1 | 16.6 | 18.0 |
| Tauranga 11 | 30.0 | 2.9% | 30.3 | 31.1 | 32.0 | 32.9 | 33.8 | 38.2 | 42.6 |
| Waihi Rd | 24.1 | 0.4% | 21.9 | 22.0 | 22.0 | 22.1 | 22.2 | 22.6 | 22.9 |
| Welcome Bay | 21.4 | 1.9% | 22.6 | 23.0 | 23.5 | 23.9 | 24.3 | 26.5 | 28.7 |

| TAURANGA AREA SUBSTATIONS | | | FORECAST MAXIMUM DEMAND [MVA] | | | | | | |
|---------------------------|-------------|-------------|-------------------------------|------|------|------|------|------|------|
| SUBSTATION | TX CAPACITY | GROWTH | 2016 | 2017 | 2018 | 2019 | 2020 | 2024 | 2030 |
| Tauranga GXP | 90.0 | 1.5% | 82.2 | 83.4 | 84.6 | 85.8 | 87.1 | 93.0 | 99.3 |

| Combined Loads | | FORECAST MAXIMUM DEMAND [MVA] | | | | | | | |
|-------------------------------|---------------------|-------------------------------|------|------|------|------|------|------|------|
| NETWORK | (N-1) Line Capacity | GROWTH | 2016 | 2017 | 2018 | 2019 | 2020 | 2025 | 2030 |
| OMO-AON-KTK-KTP (ADMD) | 25.0 | 3.2% | 24.1 | 24.5 | 24.9 | 25.2 | 25.6 | 27.5 | 29.5 |

Notes:

- Class capacity is similar to Firm Capacity and represents the capacity that can be delivered following the first outage of any major equipment. Unlike Firm Capacity it considers the deliverable capacity in the context of switching and network reconfiguration (11kV & 33kV) post-fault conditions.
- All maximum demand values are in MVA.
- Purple shaded cells indicate that the substation’s Class Capacity has been exceeded and network enhancements should be considered.
- The Tauranga GXP forecast excludes the effects of the Trustpower Kaimai Hydro Scheme (i.e. is a true representation of the consumer load).
- The after diversity maximum demand (ADMD) values based on the summation of the Omokoroa, Aongatete, Katikati and Kauri Point substations coupled with a diversity factor of ~0.85. This value is based on historical data.
- A “*” and alternate colour indicates a zone substation affected by this project.

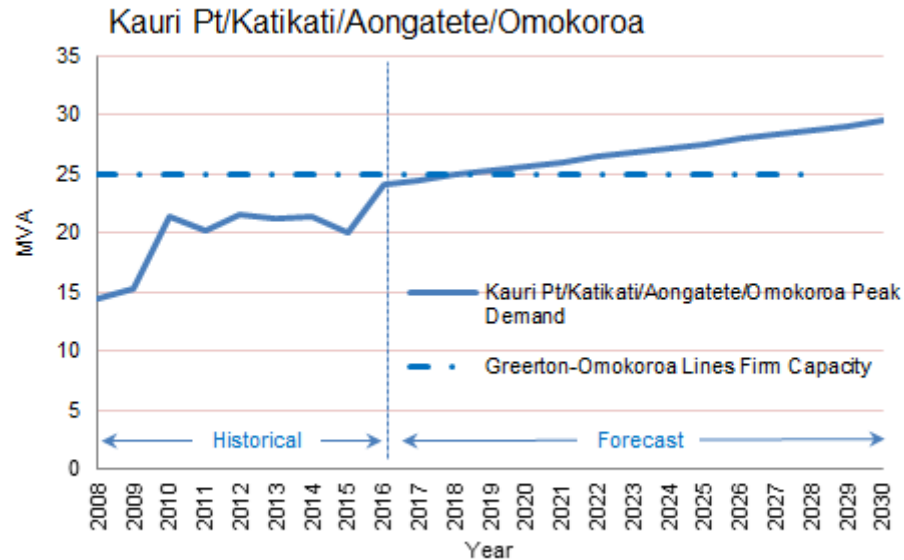

Options Analysis | Long List of Project Options | High Level Assessment

| | |
|------------------------------------|--|
| <p>Assessment Process</p> | <p>A wide range of potential options are available for the resolution of electrical network constraints. However, depending on local conditions many of the options can have significant challenges and/or shortcomings. On this basis a two tier Options Analysis is followed. In the first instance all potential options are considered against a set of high level criteria. Those options that are identified as having significant challenges and not favourable are not considered further. As a result of the process a short list of viable options is identified for further analysis.</p> |
| <p>Long List of Options</p> | <p>The following table contains a list of the high level project options that are potentially available to resolve the electrical supply issues within the northwest Tauranga area. Option 1 involves maintaining the status quo and allowing the risks associated with consumer non-supply to increase over time. Adoption of this option is possible but as a prudent network operator Powerco is of the view that following this path would not be appropriate, given the supply network would not meet with Powerco’s Security-of-Supply Standard. Option 1 is thus not short-listed. The three non-network options (Options 2, 3 and 4) are not</p> |

shortlisted on the following basis:

- Renewable generation sources are often not viable due to their intermittent nature and cost. Viable renewable generation options are also limited by the fact that the load on the northwest Tauranga area is winter peaking. Fossil fuelled generation is technically viable but not shortlisted due to cost, environmental and consenting issues.
- Fuel switching and demand side response (DSR) are considered to be deferment strategies and their viability is not certain. Powerco uses a mains-borne ripple control system to control significant amounts of hot water cylinder load on its network. During peak loading periods most hot water cylinders are turned off. The demand reduction, however, is not sufficient to alleviate the constraints. No significant/additional winter peaking consumer loads have been identified for control.

Options 7 through 9 utilise 110kV lines/cables with the objective of establishing a 110/33kV substation in the vicinity of the existing Omokoroa substation. All these options are not shortlisted on the following basis:

- The construction of new overhead 110kV lines will likely meet with significant opposition. For this reason the consenting process and the securing of land easements would be expensive.
- The construction of new underground 110kV cables would be expensive.
- The 110kV network (cables/lines) would need to extend beyond the Greerton switchyard to the Tauranga GXP. Two additional 110kV circuit bays would be required at the Tauranga GXP, which is relatively space constrained. The 110/11kV GXP could be changed to a 33/11kV one to free up two 110kV bays, but this is also an expensive option. These factors add considerable cost to the 110kV options.

Both Options 5 and 6 are shortlisted as they either make use of the existing overhead network and/or use underground 33kV cable for other sections. This will considerably lower the consenting risk. Consequently they are considered to be the most cost effective options.



Long List of Options | High Level Assessment

| Omokoroa Reinforcement Long list of projects and high level assessment | | | Assessment Criteria | | | | | | |
|--|-----|---|---------------------|----------|-----------|------|----------|------|------------|
| PROJECT FOCUS | No. | PROJECT | Fit | Feasible | Practical | GEIP | Security | Cost | Short-list |
| Do Nothing | 1 | Allow the electrical demand & risk of consumer non-supply to increase | ✗ | ✓ | ✓ | ✗ | ✗ | ✓ | ✗ |
| Non-network: | 2 | Distributed Generation (DG) including peak lopping generation | ✗ | ✓ | ✗ | ✓ | ✓ | ✗ | ✗ |
| | 3 | Fuel switching to reduce electrical demand | ✓ | ✗ | ✗ | ✓ | ✓ | ✗ | ✗ |
| | 4 | Demand Side Response (DSR) | ✓ | ✗ | ✗ | ✓ | ✓ | ✗ | ✗ |
| Reinforcement | 5 | Two new 33kV OMO-GRE Circuits | ✓ | ✗ | ✗ | ✓ | ✓ | ✓ | ✓ |
| | 6 | Third 33kV OMO-GRE Circuit | ✓ | ✓ | ✓ | ✓ | ✓ | ✓ | ✓ |
| | 7 | Upgrade Existing 33kV OMO-GRE Circuits to 110kV | ✓ | ✓ | ✓ | ✓ | ✓ | ✗ | ✗ |
| | 8 | Construct New 110kV OMO-GRE O/H Line plus 110/33kV Substation | ✓ | ✓ | ✗ | ✓ | ✓ | ✗ | ✗ |
| | 9 | Staged/hybrid 33kV & 110kV Upgrade | ✓ | ✓ | ✓ | ✓ | ✓ | ✗ | ✗ |

Key:

- Fit: Fit for Purpose: Does the option address the need appropriately and does it fit with other developments in the vicinity.
- Feasible: Technically Feasible: Consider the complexity, future adaptability, and whether it aligns with company standards, strategies and policies.
- Practicality: Practical to Implement: Are there potential environmental or property issues which may be insurmountable. Can it be achieved in the required time frame.
- GEIP: Good Electricity Industry Practice (GEIP): Good practice (technically and environmentally) and in terms of AM practice (capacity, age, technological, safety)
- Security: Security and Reliability: Does the option provide adequate levels of security and appropriate reliability considering the demand, load type and future growth.
- Cost: Some options will intuitively be known to be far more expensive than other options, and this may preclude them.

| Options Analysis Short List of Options | | |
|---|---------|---|
| Option | Cost* | Description |
| <p>Option 5:</p> <p><i>Two new 33kV Greerton-Omokoroa Circuits – Composite Overhead/Underground</i></p> | \$12.2M | <p>This option involves the construction of two new 12km, 33kV circuits from the Greerton switchyard to the Omokoroa substation. The Omokoroa substation would be supplied independently by these two new circuits (i.e. the existing 33kV tee connected circuits would be removed) and the Aongatete, Katikati and Kauri Point substations would remain supplied via the existing 33kV network.</p> <p>There are a number of urban areas between Greerton and Omokoroa, which means construction and installation of overhead lines across/over these areas is likely to result in significant consenting/consultation costs. Therefore, for the purposes of this analysis, the costs are based on 33kV underground cables.</p> <p>Two new 33kV circuit breakers will need to be required at the Greerton switchyard.</p> |
| <p>Option 6:</p> <p><i>One new 33kV Greerton-Omokoroa Circuit/Reconfiguration of existing Greerton-Omokoroa Circuits</i></p> | \$11.4M | <p>This option involves the construction of two new 33kV circuits in conjunction with a reconfiguration of the existing Greerton-Omokoroa B and Greerton-Bethlehem lines.</p> <p>The new circuit between Greerton Switching Station and Omokoroa substation will involve the following work:</p> <ul style="list-style-type: none"> • Construction of a single 33kV underground circuit, length 8km, with a rating of 30MVA from Wairoa Rd to the Omokoroa substation. The cable would connect to the existing overhead GRE-BTM 33kV line at Wairoa Rd • Construction of a single 33kV underground circuit, length 5km, with a rating of 30MVA between the Greerton switching station and the Bethlehem substation. The installation of this cable would achieve the following two outcomes: <ul style="list-style-type: none"> ○ Release an existing 33kV overhead line (GRE-BTM) that crosses the Wairoa River. ○ Reduced coupling between the Omokoroa and Bethlehem 33kV rings, eliminating potential for sympathy tripping. • Installation of a new 8 x 33kV, indoor switchboard at the Omokoroa substation. The existing land does not allow the extension of the existing 33kV air insulated switchyard, which contains two outdoor 33kV circuit breakers. • Installation of fibre circuits/links between Greerton and both Bethlehem and Omokoroa. These fibre cables would be installed in the above mentioned cable trenches. This would enable fast unit protection to be implemented on the lines/cable that run between Greerton & Bethlehem and Greerton & Omokoroa. This enhancement would significantly reduce the complexity of the existing protection systems and significantly reduce the chances of false tripping of these lines/cables. <p>The north-western section of the existing overhead 33kV Greerton-Bethlehem line would not be required (in terms of use for the sub-transmission network). However, the line would continue to be useful and Powerco plans to energise the line at 11kV for use</p> |

| | | |
|--|--|---|
| | | as an express 11kV feeder from the Bethlehem substation |
|--|--|---|

Option Analysis | Advantages vs Disadvantages

The following sections summarise the advantages/disadvantages associated with the short listed options. The intention being to also capture project risks and inter-dependencies.

| Option | Advantages | Disadvantages |
|---|---|--|
| <p>Option 5:</p> <p><i>Two new 33kV Greerton-Omokoroa Circuits – Composite Overhead/Underground</i></p> | <ul style="list-style-type: none"> Improves network reliability to required Powerco security levels Practical and achievable in terms of consenting and routes. Utilises known technology and proven designs. Removes the existing overhead 33kV tee connections on the Greerton-Omokoroa circuits (into the Omokoroa substation). | <ul style="list-style-type: none"> There are two sections of privately owned land of 0.3km and 0.5km across which the cable circuits will cross and thus, easements from these property owners will need to be secured. River crossing (Wairoa River) will be required |
| <p>Option 6:</p> <p><i>One new 33kV Greerton-Omokoroa Circuit/Reconfiguration of existing Greerton-Omokoroa Circuits. Refer to Figure 2 & Figure 4</i></p> | <ul style="list-style-type: none"> Improves network reliability to required Powerco security levels The new underground cable circuit will improve reliability to the Bethlehem substation. Makes use of an existing 33kV line that crosses the Wairau River and avoids uncertainty associated with securing consents/easements for an additional river crossing. The new circuits are of fully or partial underground construction. This should improve network reliability. Practical and achievable in terms of consenting and routes. Utilises known technology and proven designs. Delivers simple & reliable protection system. Removes sympathetic tripping problem caused by mutual coupling. Removes an existing overhead 33kV tee connection on the Greerton-Omokoroa circuits. | <ul style="list-style-type: none"> Early retirement of the existing outdoor 33kV switchyard. The switchyard is presently equipped with two circuit breakers. The first a 1200Amp, Siemens CB (installed in 2012) and the second a 400Amp, Takaoka CB (installed in 1984). |

| | | |
|-------------------------------|--|--|
| <p>Shared Features</p> | <ul style="list-style-type: none"> • Practical and achievable in terms of consenting and routes. • Utilises known technology and proven designs. • Delivers simple & reliable protection system. • Removes the existing overhead 33kV line Tee’s on the GRE-OMO lines (into the Omokoroa substation). • Removes the sympathetic tripping problem caused by mutual coupling. | |
|-------------------------------|--|--|

| <p>Preferred Option(s)</p> | |
|---|--|
| <p>Preferred Option</p> | <p>Option 6 : One new 33kV Greerton-Omokoroa Circuit/Reconfiguration of existing Greerton-Omokoroa Circuits</p> |
| <p>Reasons for choosing Option</p> | <p>Option 6 is determined to be the most economic option. It has the following benefits and advantages over the other options considered:</p> <ul style="list-style-type: none"> • The lowest capital overall cost. • Leverages off the thermally upgraded capacity of the existing 33kV Greerton-Omokoroa circuits. • The highest economic net benefits in terms of reliability cost savings. • Delivers lower electrical losses. • Lowest consenting risks. |



Project Name: PoD-G05 Omokoroa

| Item | Description | Actual Cost | Projected Cost |
|------|---|-------------|----------------|
| A | Property & Consent Costs | | |
| A.1 | Land owner agreements | \$0 | \$248,787 |
| B | Investigation and Reporting Costs | | |
| B.1 | Concept Design Report (CDR) | \$0 | \$20,000 |
| C | Substation Costs | | |
| C.1 | None required (Cable protection included in D.1 below) | \$0 | |
| D | Line and Cable Costs | | |
| D.1 | Omokoroa 33kV Switchroom/Switchboard | - | \$2,189,684 |
| D.2 | 33kV Cable and Fibre Circuit : Omokoroa Substation to Wairoa Rd | - | \$4,639,300 |
| D.3 | 33kV Cable and Fibre Circuit : Bethlehem-Greerton | - | \$3,306,600 |
| D.4 | Fibre Circuit : Bethlehem-Wairoa | - | \$148,200 |
| D.5 | 33kV Cable Circuit : Aongatete-Omokoroa 1 | - | \$423,700 |
| D.6 | 33kV Cable Circuit : Aongatete-Omokoroa 2 | - | \$423,700 |
| E | Committed/Historical Costs (A+B+C+D) | \$0 | |
| F | Future Projected Costs (A+B+C+D) | | |
| G | Anticipated Final Cost (E+F) | | \$11,399,971 |



| Implementation Plan | | | | |
|--|-------------------------|-----------------------|------------------------|--|
| Project or Action | Start Year ¹ | End Year ¹ | NZ \$'000 ¹ | Details / Comments |
| Project costs to date | - | FY16 | \$0 | Costs that have already occurred. |
| Land/easements & preliminary investigations | FY19 | FY19 | \$249 | Cost to secure substation land and cable routes/easements. |
| Concept Design Report (CDR) | FY19 | FY19 | \$20 | Establish concept for tender documents - external resource |
| Omokoroa 33kV Switchroom/Switchboard | FY20 | FY21 | \$2,190 | Switchroom, switchboard, site preparation, earthing etc. |
| Bethlehem-Greerton 33kV Cable & Fibre | FY20 | FY21 | \$3,307 | A 5.0km single cct, 630mm ² AL, underground cable through suburban areas |
| Omokoroa Sub-Wairoa Rd 33kV Cable & Fibre | FY19 | FY21 | \$4,639 | A 9.3km single cct, 630mm ² AL, underground cable through suburban, rural areas |
| Bethlehem-Wairoa Fibre | FY19 | FY19 | \$148 | A 3km overhead fibre strung on existing 33kV overhead line |
| Aongatete-Omokoroa-1 33kV Cable Circuit | FY22 | FY22 | \$424 | A 1km single cct, 630mm ² AL, underground cable to remove existing hard Tee |
| Aongatete-Omokoroa-2 33kV Cable Circuit | FY22 | FY22 | \$424 | A 1km single cct, 630mm ² AL, underground cable to remove existing hard Tee |
| Total Project Costs → | FY19 | FY22 | \$11,400 | Includes Only Growth & Security Expenditure. |

Supporting Documents and Models

| | |
|--|--|
| <p><i>Planning documents Standards Policies Reviews and Consultant reports Concept Designs Estimates</i></p> | <ol style="list-style-type: none"> 1. Area Study: Greerton/Omokoroa 33kV Reinforcement,16/09/2014. 2. Tauranga Long Term Development Plan. 3. Powerco Network Development Plan 2017 (NDP). 4. Powerco’s Demand Forecast. 5. Powerco’s 2016 Asset Management Plan (AMP). 6. “310S001 Security-of-Supply Classifications – Zone Substations”, Powerco Standard. 7. “393S041 Zone Substation Transformer Ratings”, Powerco Standard. 8. “393S035 Electrical network Conductor Rating Standard”, Powerco Standard. |
|--|--|

Notes/Assumptions

| | |
|---|--|
| <p><i>Generic Assumptions in relation to Options Costs</i></p> | <ul style="list-style-type: none"> • Costs are expressed in 2016 (real) dollars. • The costs quoted are to construct the network and do not include economic factors (i.e. costs of non-supply) • The capital costs fall within the Growth and Security expenditure categories only. • The capital costs only include Powerco’s capital expenditure (not Transpower or other parties). • The costs include all costs associated with the proposed projects (or alternate options) regardless of whether those costs fall within the CPP period or not. |
| <p><i>Specific Assumptions in Relation to Options Costs</i></p> | <ul style="list-style-type: none"> • Cost estimation for the options has initially been achieved via a desktop study using Powerco’s standard building block unit costs. The costs have then been refined by further investigations. • Property and consenting costs are usually a high risk area involving considerable uncertainty. Due to the urban/lifestyle-block nature of area underground cable is used and where possible installed in road reserve. • The costs in this POD may differ from those in the detailed Options Analysis document. This is because some of the costs have been further reviewed and refined to confirm the preferred solution. The refined costs have been checked against the estimates used in the Options Analysis to ensure that it does not materially impact the Option Analysis outcomes and that the preferred solution still ranks higher than alternatives. • The option analysis was done before the thermal upgrade of the existing Greerton-Omokoroa circuits was completed so this was included as part of a solution option. The thermal upgrade project has since been completed and the costs have been allocated to the routine projects budget. Again, the Option Analysis has been reviewed to ensure this change does not materially affect the outcome with regard to the solution preference. |



Figure 1 Existing Omokoroa/Aongatete/Katikati/Kauri Pt Sub-transmission Network: Geographic Diagram⁷

⁷ The (N-1) contingency rating of the OMO-GRE A and B circuits is 25MVA.

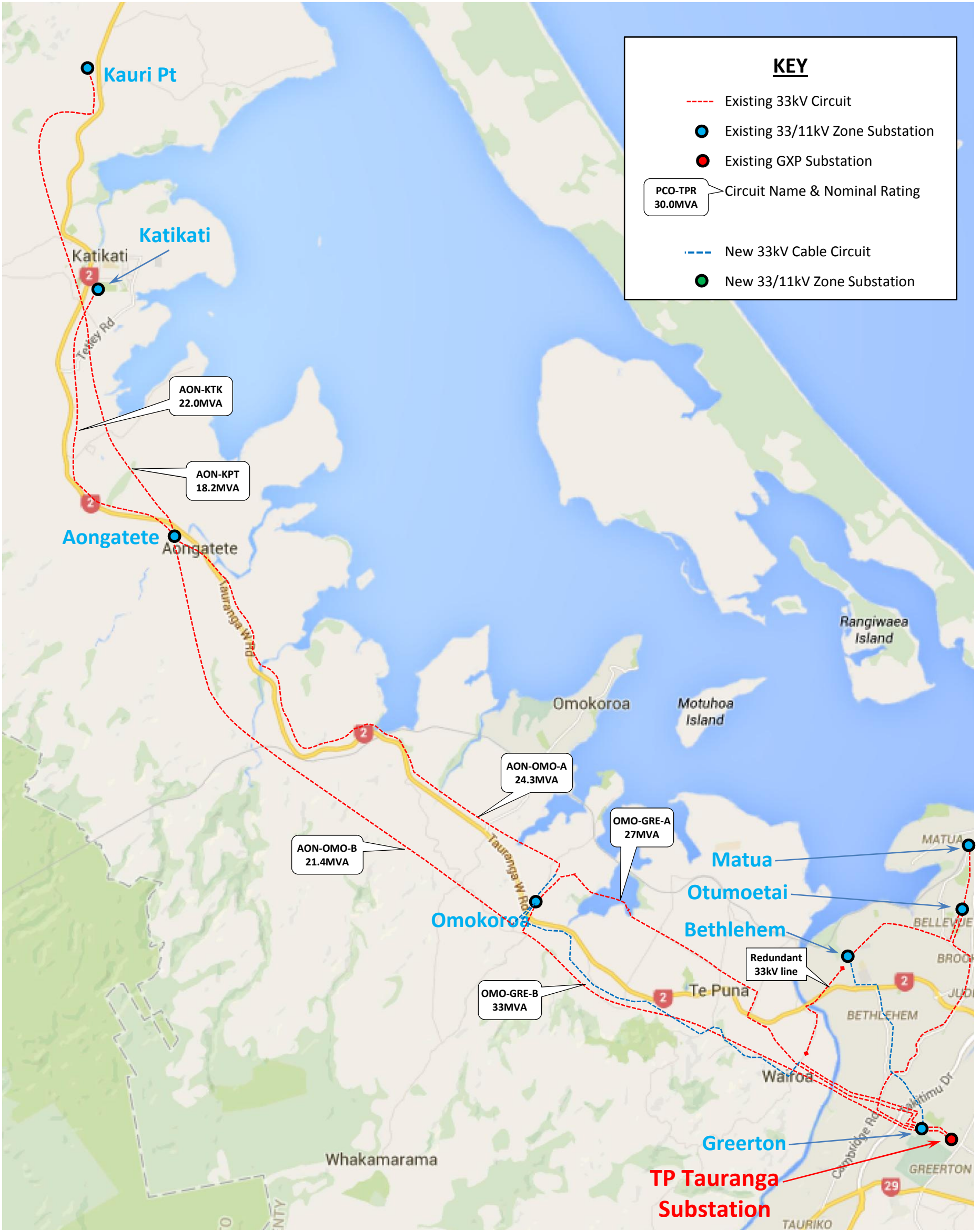

Figure 2: Option 6 -Third Greerton-Omokoroa 33kV Circuit: Geographic Diagram⁸

⁸ The (N-1) contingency rating of the OMO-GRE A and B circuits is 25MVA

Figure 3 Existing Omokoroa/Aongatete/Katikati/Kauri Pt Sub-transmission Network: One-Line Diagram

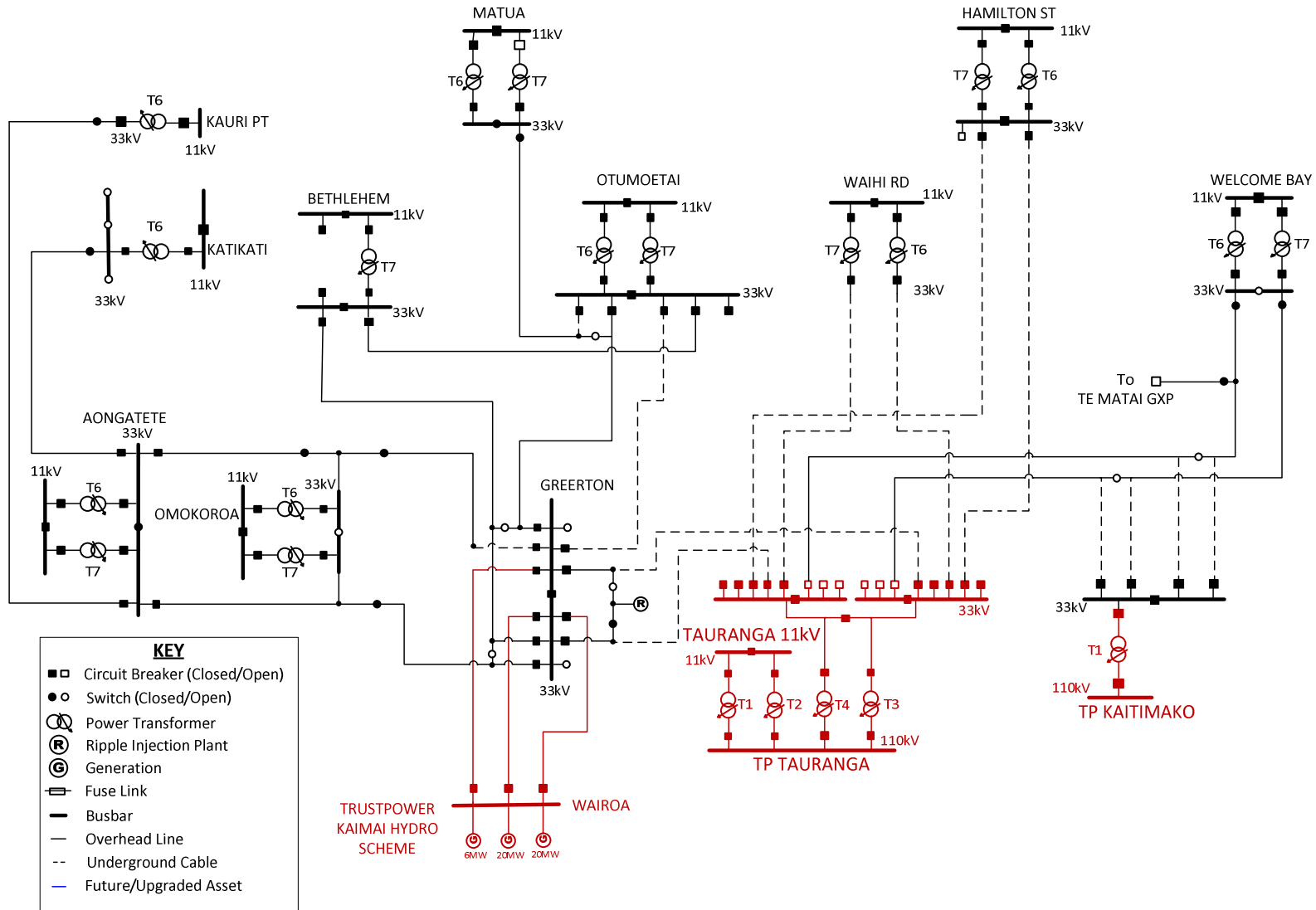

Figure 4: Option 6 - Third Greerton-Omokoroa 33kV Circuit- One-Line Diagram

Omokoroa/Aongatete/Katikati/Kauri Pt Reinforcement

