



**TSLRIC price review determination
for the Unbundled Copper Local
Loop and Unbundled Bitstream
Access services**

Model Specification

Commerce Commission

Ref: 2014-20-DB-ML – BU models

Public Version

TERA Consultants

39, rue d'Aboukir

75002 PARIS

Tél. + 33 (0) 1 55 04 87 10

Fax. +33 (0) 1 53 40 85 15

www.teraconsultants.fr

S.A.S. au capital de 200 000 €

RCS Paris B 394 948 731

November 2014

Summary

0	Introduction.....	6
0.1	Background.....	6
0.2	Structure of this document	7
1	Overview of the modelling approach.....	8
1.1	Introduction.....	8
1.2	Implementation of the modified scorched node approach	8
1.2.1	The modified scorched node approach for the modelling of the copper network	8
1.2.2	The modified scorched node approach for the modelling of the fibre network	9
1.3	Opex modelling approach	9
1.4	Demarcation point between access and core.....	10
1.5	Access network modelling approach.....	11
1.5.1	Modelling approach.....	11
1.5.2	Steps of the access network modelling	13
1.5.2.1	Node location and coverage.....	13
1.5.2.2	Network deployment at street level	14
1.5.3	Full network.....	16
1.5.4	Current asset prices	16
1.5.5	Capex	16
1.5.6	Depreciation.....	16
1.5.7	Opex calculation.....	16
1.5.8	Network cost allocation	16
1.6	Core network modelling approach.....	17
2	Opex model.....	19
2.1	Opex data	19
2.2	Network expenses	19
2.2.1	Electricity and buildings expenses.....	19
2.2.2	Other expenses.....	19
2.3	Non-network expenses	20
2.3.1	Type of costs.....	20
2.3.2	Approach.....	20
2.3.3	Allocation of non-network costs between regulated and unregulated services	21
3	Geospatial	22
3.1	Reference files.....	22
3.2	Issues with the geospatial data	23
3.2.1	Road network.....	23
3.2.2	Notional exchanges.....	24
3.2.3	Holes and overlaps in the coverage of the exchange area definitions ..	24
3.2.4	Exchange site not in exchange area.....	26

3.2.5	Multipart discontinuous exchanges.....	26
3.2.6	Exchange adjustments due to road network model	27
3.3	Copper network	28
3.3.1	SC coverage areas	28
3.3.2	Distribution	30
3.3.3	Feeder	30
3.4	Fibre network.....	31
3.5	Inter-exchanges links	31
3.6	DWDM links	32
3.7	Submarine links	32
3.8	Access part of the fibre leased lines.....	32
3.9	Fixed wireless access	33
3.9.1	FWA coverage	33
3.9.2	Connection of the FWA sites	33
4	Equipping the copper access network	34
4.1	Demand for the copper access network	34
4.1.1	Actual demand	34
4.1.2	Forecast demand	34
4.2	Copper network	34
4.3	Network dimensioning.....	36
4.3.1	Section configuration.....	36
4.3.2	Cables.....	37
4.3.2.1	Lead-in.....	37
4.3.2.2	Distribution	38
4.3.2.3	Feeder	38
4.3.3	Joints	38
4.3.3.1	Lead-in.....	38
4.3.3.2	Distribution.....	39
4.3.3.3	Feeder	39
4.3.4	Civil engineering.....	40
4.3.4.1	Aerial versus underground	40
4.3.4.2	Poles.....	40
4.3.4.3	Ducts.....	41
4.3.4.4	Trenches.....	42
4.3.4.5	Chambers	43
4.4	Civil engineering sharing.....	43
4.4.1	Civil engineering sharing with the core network.....	43
4.4.2	Civil engineering sharing with the access part of leased lines	43
4.4.3	Civil engineering sharing with utilities	43
5	Equipping the fibre access network	45
5.1	Demand for the fibre access network.....	45
5.1.1	Current demand	45
5.1.2	Forecast demand	45
5.2	Fibre network.....	45
5.3	Network dimensioning.....	46

Model Specification – Public Version

5.3.1	Section configuration.....	46
5.3.2	Cables.....	46
5.3.2.1	Lead-in.....	46
5.3.2.2	Distribution.....	46
5.3.3	Joints.....	47
5.3.3.1	Lead-in.....	47
5.3.3.2	Distribution.....	47
5.3.4	Civil engineering.....	47
5.3.4.1	Aerial versus underground.....	47
5.3.4.2	Poles.....	47
5.3.4.3	Ducts.....	47
5.3.4.4	Trenches.....	48
5.3.4.5	Chambers.....	48
5.4	Civil engineering sharing.....	48
6	Equipping the fixed wireless access network.....	49
6.1	Demand for the fixed wireless access network.....	49
6.1.1	Current demand.....	49
6.1.2	Forecast demand.....	49
6.2	Fixed wireless access network.....	49
6.3	Network dimensioning.....	50
6.3.1	Base stations.....	50
6.3.2	Cables.....	50
6.3.3	Joints.....	50
6.3.4	Civil engineering.....	50
6.4	Civil engineering sharing.....	51
7	Equipping the core network.....	52
7.1	Structure of the network.....	52
7.2	Number of subscribers.....	54
7.3	Engineering rules of active assets.....	54
7.3.1	DSLAMs.....	54
7.3.1.1	DSLAMs at cabinet.....	55
7.3.1.2	DSLAMs at Exchange.....	55
7.3.2	FDS.....	56
7.4	Civil engineering.....	57
7.4.1	Trenches, ducts and cables.....	57
7.4.1.1	Cables.....	57
7.4.1.2	Trenches, ducts and manholes.....	58
7.4.2	Other links.....	58
8	Network and services costing.....	59
8.1	Unit costs input.....	59
8.1.1	Unit costs.....	59
8.1.2	Copper cable unit costs.....	59
8.1.3	Trenching unit costs.....	60
8.2	Spectrum costs for FWA.....	60
8.3	Price trends.....	60

TSLRIC price review determination for the Unbundled Copper Local Loop and Unbundled
Bitstream Access services
Model Specification – Public Version

8.4	Asset lives	63
8.4.1	Asset lives for the TERA Access Network	63
8.4.2	Asset lives for the TERA Core Network.....	63
8.5	Cost of capital.....	64
8.6	Annuity calculations	64
8.6.1	Time to build	64
8.6.2	Tax depreciation rates.....	64
8.6.3	Adjustment to pre-tax annuity.....	66
8.6.4	Post-tax real WACC.....	66
8.6.5	Annuity.....	66
8.7	Cost allocation	66
8.7.1	Capacity-based allocation for UCLL	66
8.7.2	Capacity-based allocation for UBA	67
8.7.2.1	Active assets.....	67
8.7.2.2	Passive assets.....	67
8.8	Indirect capex costs	68
8.9	Services costing.....	69
8.9.1	Costing of the UBA.....	69
8.9.2	Costing of the UCLL and the SLU	69
8.9.2.1	Lowest cost roll-out scenario.....	69
8.9.2.2	Double recovery between UCLL and UBA	69
8.9.2.3	Selecting the cheapest configuration.....	70
8.9.2.4	Costing the UCLL and the SLU	71
9	Verifications.....	72
9.1	Cost recovery.....	72
9.2	Cross-checks.....	72
9.2.1	Access network dimensioning	72
9.2.2	Core model	75
10	Prices	76
10.1	Price control period	76
10.2	Prices over the price control period.....	76
10.3	Gradients.....	76
10.4	Results.....	77
10.5	Sensitivity analysis.....	77
10.5.1	Sensitivity to the geographic scope: TSO-derived boundary.....	77
10.5.2	Sensitivity to the share of overhead network	78
10.5.3	Sensitivity to price trends	79
10.5.4	Sensitivity to asset lives	79
10.5.5	Sensitivity to the capital contribution for RBI DSLAM.....	79
10.5.6	Sensitivity to the cost adjustment method to select the cheapest technology.....	80
10.5.7	Sensitivity to the Exchange-to-FDS link allocation.....	81

0 Introduction

0.1 Background

Unbundled Copper Local Loop (UCLL) and Unbundled Bitstream Access (UBA) are services that allow alternative operators' access to the local loop infrastructure of Chorus.

The Telecommunications Act 2001 (the Act) requires the Commerce Commission (the Commission) to determine a price for the UCLL and UBA services. In the first instance the Commission is required to benchmark prices against comparable countries under the 'initial pricing principle' (IPP). If an access seeker or Chorus Limited is not satisfied with the price (either the UCLL or UBA) determined under the IPP, the Act provides that the party can ask the Commission to calculate a price for that service in accordance with the 'final pricing principle' (FPP), which is Total Service Long Run Incremental Cost (TSLRIC) for UCLL and UBA.

The Commission reviewed the benchmarked UCLL price on 3 December 2012 and determined the UBA benchmarked price on 5 November 2013. However, the Commission has received FPP requests both for UCLL and UBA: the UCLL FPP request was received in February 2013, the UBA FPP request was received in January 2014. Therefore, the Commission needs to determine a price for the UCLL and UBA services in accordance with the FPP.

TERA Consultants (TERA) has been mandated by the Commission to calculate a price for the UCLL and UBA services in accordance with the FPP which is TSLRIC.

A consultation paper on conceptual issues of UCLL cost modelling was issued by the Commission in December 2013. A further consultation paper focusing on UBA¹ was also issued in early February 2014. Responses from interested parties were received in February 2014.

The Commission issued a paper which set out its preliminary views on its proposed regulatory framework for the UCLL and UBA TSLRIC cost modelling exercises and its preliminary views on a number of fundamental assumptions for the development of a TSLRIC cost model for the UCLL and UBA services². Having reviewed the Commission paper, TERA has provided its views on some key methodological choices related to the calculation of TSLRIC in the document "Modern Equivalent Assets and relevant scenarios".

The Commission sought the view of interested parties on all topics and has reviewed the submissions and the cross-submissions sent by all the interested parties.

¹ Commerce Commission, Determining a TSLRIC price for Chorus' unbundled bitstream access service under the final pricing principle, (7 February 2014)

² Commerce Commission, Consultation paper outlining our proposed view on regulatory framework and modelling approach for UBA and UCLL services, (9 July 2014)

Based on these consultations and on the papers previously published, the Commission has made a number of decisions regarding the modelling and the pricing of the different regulated services. These decisions define the criteria for developing the access network cost model and the core network cost model. They are listed in the Model Reference Paper.

Based on the Model Reference Paper, this document is describing the specifications that have been followed to derive the price of the different regulated services.

The details of the modelling are described in the model documentation.

0.2 Structure of this document

This Model Specification details the specifications followed when building the cost models. The paper has the following structure:

- **Section 1** – Overview of the modelling approach (see §1): it gives a high level view of the approach followed;
- **Section 2** – Opex model (see §2): it describes how the opex part and the non-network costs shall be calculated;
- **Section 3** – Geospatial (see §3): it details the geospatial work that has been carried out as offline calculations and that feeds the access network cost model;
- **Section 4** – Equipping the copper access network (see §4): it details the dimensioning of the copper access network;
- **Section 5** – Equipping the fibre access network (see §5): it details the dimensioning of the fibre access network;
- **Section 6** – Equipping the fixed wireless access network (see §6): it details the dimensioning of the fixed wireless access network;
- **Section 7** – Equipping the core network (see §7): it details the dimensioning of the core network;
- **Section 8** – Network and services costing (see §8): it derives the cost of the network and the different services;
- **Section 9** – Verifications (see §9): it details the cross-checks that have been carried out to validate the modelling; and
- **Section 10** – Prices (see §10): it describes how the prices of the different regulated services are set.

1 Overview of the modelling approach

This section provides an overview the modelling approach of the access network cost model, the core network cost model and the opex model.

1.1 Introduction

The model is a combination of five interlinked parts:

- **Geospatial data-processing** (offline calculation): aims at determining all cable paths from the end-users dwellings to the network nodes (shortest path algorithms). Dedicated geospatial tools (such as QGIS or MapInfo) are used to perform these offline calculations;
- **Access network dimensioning** (Microsoft Access): based on the geospatial data analysis, the access network is dimensioned (cables, civil engineering, etc.). Due to large amount of data to be treated, the calculation is performed within Microsoft Access;
- **Access network costing** (Microsoft Excel): once the dimensioning is performed, costs are derived (multiplying the network inventory by the unit costs). The maximum amount of calculations (including investment calculation) is done in Microsoft Excel as Microsoft Excel is more transparent than Microsoft Access;
- **Opex model** (Microsoft Excel): based on Chorus; financial information, the opex and the non-network costs are derived for each service; and
- **Core network** (Microsoft Excel): dimensions and derives the costs of the core network and derives the price of each service.

1.2 Implementation of the modified scorched node approach

Consistent with criteria 24 and 25 of the Model Reference Paper, the model follows the modified scorched node approach, i.e. the model is using as a starting point the exchanges of Chorus' existing network and their coverage areas. However when inefficiencies are found, the nodes and their coverage areas are modified. These inefficiencies are generally the results of:

- The lack of precision of the data collected; and
- The history of the network roll-out.

1.2.1 The modified scorched node approach for the modelling of the copper network

As described in §4.2, the copper network comprises three layers of nodes:

- The Main Distribution Frame (MDF);

- The Street Cabinet (SC); and
- The distribution point (the Copper Cable Terminal or CCT).

Following the modified scorched node approach the location of these nodes has been used as the starting point of the geospatial work, except for CCT that are deployed on a bottom-up basis. The coverage areas have also been used in order to split the country between the different MDF.

Chorus (like most operators around the world) has been unable to provide the coverage areas of the SC. The determination of the SC coverage areas is therefore part of the geospatial work as described in §3.3.1

1.2.2 The modified scorched node approach for the modelling of the fibre network

The fibre modelling comprises two layers of nodes:

- The Optical Distribution Frame (ODF); and
- The distribution points (the Fibre Access Terminal or FAT).

Following the scorched node approach, based on the regulated (copper) network and in line with criterion 25 of the Model Reference Paper, the copper nodes and their coverage areas have been used as the basis for the fibre nodes and their coverage areas as described in the Model Reference Paper.

As described in §5.2, the fibre network comprises two layers, the ODF and the FAT. The street cabinets are therefore not relevant, only the location of the MDF.

The fibre modelling scenario includes also the Fixed Wireless Access (FWA) technology. The FWA modelling requires specification of the location of the base stations and their coverage areas.

Following the modified scorched node approach, the starting point of the FWA modelling is therefore the actual existing FWA sites and their coverage areas, i.e. the location of Vodafone's base stations that are part of the RBI program and their coverage areas.

1.3 Opex modelling approach

The Opex model implements the allocation to the UCLL and UBA services of a proportion of Chorus' expenses related to their regulated and unregulated activities, adjusted for the greater efficiencies of a new network. The depreciation costs fall within the scope of the network cost models themselves.

The information to develop a bottom-up model for operating costs is not always available. It is available for expenses such as power costs or space rental costs. However, the majority of opex are either supplier costs or staff costs. For those costs, the best practice is generally to use top-down data. Hence, a mixture of bottom-up approach and top-down approach with evolution over the time (forecasts) is carried out.

In addition, it must be underlined that a bottom-up model assesses the cost of a ‘new’ network (with potentially high capex and low opex) whereas top-down costs reflect the costs of an older network (with potentially lower capex and higher opex).

The opex modelling is mainly based on Chorus’ 2014 accounts. Expenses related to network activities have to be distinguished from expenses related to “non-network” activities.

Chorus provided separate network opex and non-network opex files.

As a consequence, the following steps are followed in the Opex model (see the figure below):

- Identify the relevant network opex for the network cost models;
- Allocate these costs between the different services by splitting those operating expenses to the different equipment;
- Adjust top-down costs to reflect relevant costs for bottom-up modelling;
- Identify the relevant non-network opex for the bottom-up model and allocate those costs to the different relevant services;
- Calculate specific costs (indirect capex) that are inputs for the core network cost model.

Figure 1 – Model opex approach

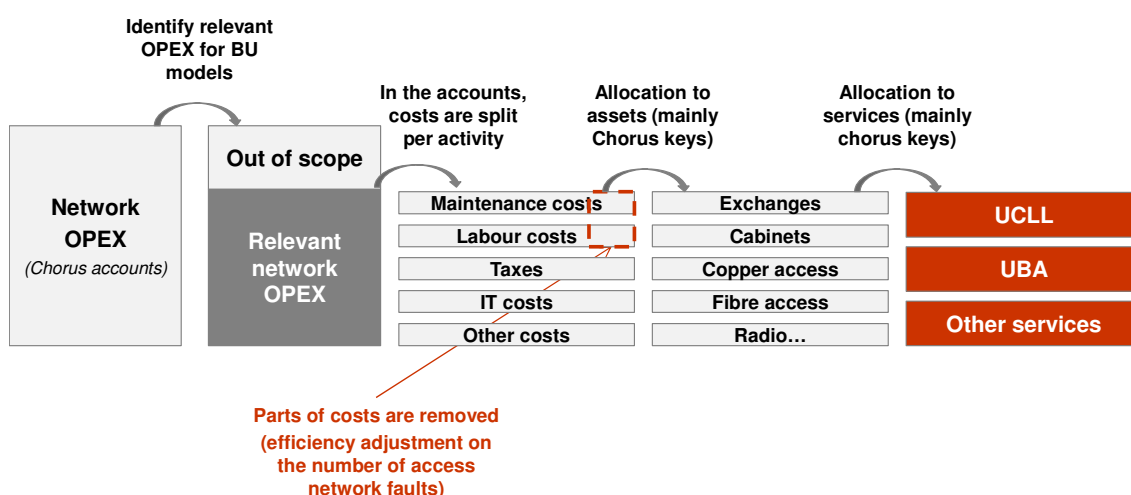

Source: TERA Consultants

Once costs are allocated to equipment, these are then allocated to the different regulated services using a routing matrix.

1.4 Demarcation point between access and core

In line with criterion 1 and criterion 2 of the Model Reference Paper, the core network cost model contains the dimensioning of all the active assets required to provide the UBA service whereas the access network cost model contains the dimensioning of all

the passive assets. The access network cost model therefore contains the dimensioning of all the passive assets located between the customers' dwellings and the MDF/ODF located in the exchanges.

Some of the passive assets are used by the UBA service but are dimensioned in the access network cost model because there are some economies of scope that should be taken into account.

E.g. the fibre cables used to link core sites together are part of the core network. However they are using the same trenches as the access network. These cables are therefore modelled in the access network in order to take into account the relevant economies of scope.

The following figure shows the demarcation point between access and core networks (regulated and unregulated).

Figure 2 – Demarcation point

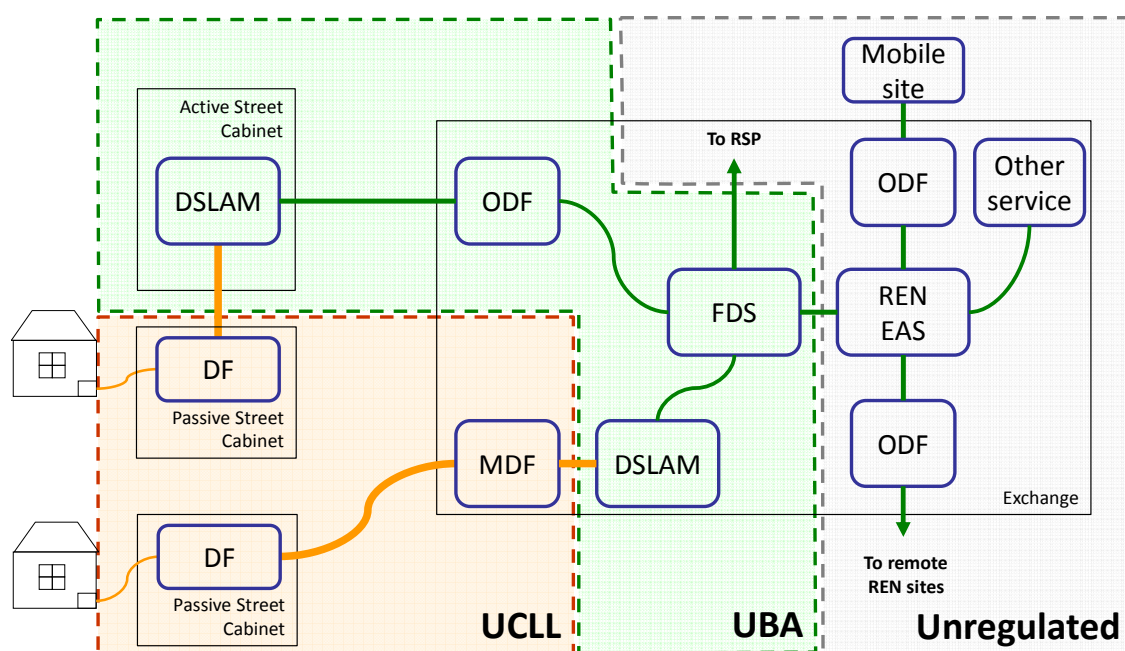

Source: TERA Consultants

1.5 Access network modelling approach

1.5.1 Modelling approach

The access network modelling approach is based on the three following principles:

1. Fixed wired access networks are dimensioned based on all dwellings located in the areas covered (and not only on the basis of the current demand);
2. Fixed wired access networks follow streets and roads (like electricity distribution networks but unlike electricity transmission networks); and

3. The path followed by the cable connecting any dwelling to a network aggregation point is the shortest path (optimisation of the network length in order to ensure the best quality of service).

Fixed wired asset network costs are mainly made of:

- Civil engineering assets (poles, ducts, trenches) cost, which depends on:
 - The length of streets/roads;
 - The unit costs which vary from country to country (mainly based on local wages); and
 - The number and size of telecommunications cables which they support.
- Cable cost which depends on:
 - The length of streets/roads;
 - The unit costs of laying cables which vary from country to country (mainly based on local wages);
 - The unit cost of cables which is quite similar from one country to another; and
 - The number of dwellings served by these cables.

This means three main types of data are needed:

- Roads length;
- Unit costs;
- Paths between dwellings and network points.

The access network modelling follows a 3-part and 8-step approach (see figure below):

- The network dimensioning phase derives the number of assets based on the total demand (steps 1 to 3);
- The network costing phase derives the yearly cost of the network based on the network dimensioning and on the unit costs (steps 4 to 7); and
- The network cost allocation phase derives the price of the different services (step 8).

Figure 3 - Access network modelling approach

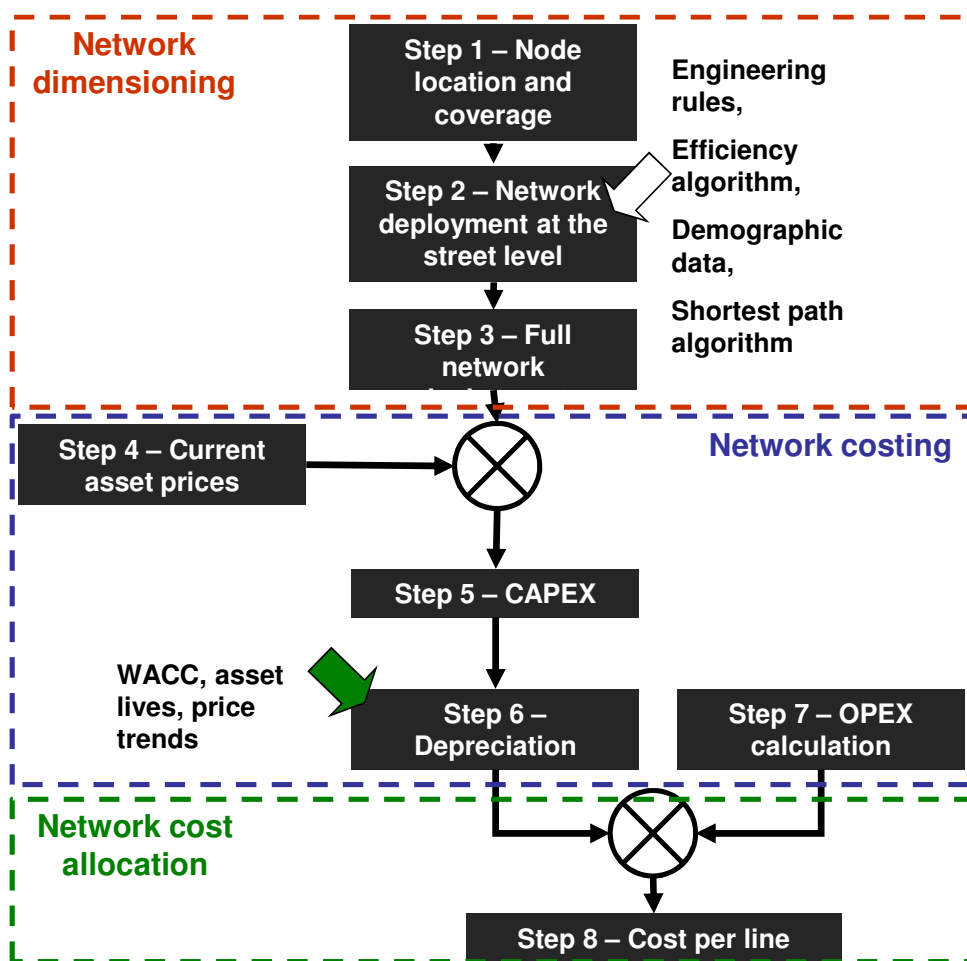

Source: TERA Consultants

1.5.2 Steps of the access network modelling

1.5.2.1 Node location and coverage

In line with criterion 25 of the Model Reference Paper, the starting point of the network dimensioning phase is the set of node locations and the set of coverage areas.

Following the modified scorched node approach, the model uses the nodes of the operator (Chorus) for:

- Identification of the MDF (exchange) positions; and
- Identification of the SC positions, in the copper network.

The identification of the MDF positions allows splitting the country into MDF areas (or exchange areas). All the end-users inside the same MDF area are connected to the same MDF.

In the copper network, the identification of SC positions allows splitting the MDF areas into SC coverage areas. All end-users inside the same SC area are connected to the same SC. As some end-users are directly connected to the MDF, the MDF is also considered as being a SC.

Figure 4 - MDF and SC coverage areas

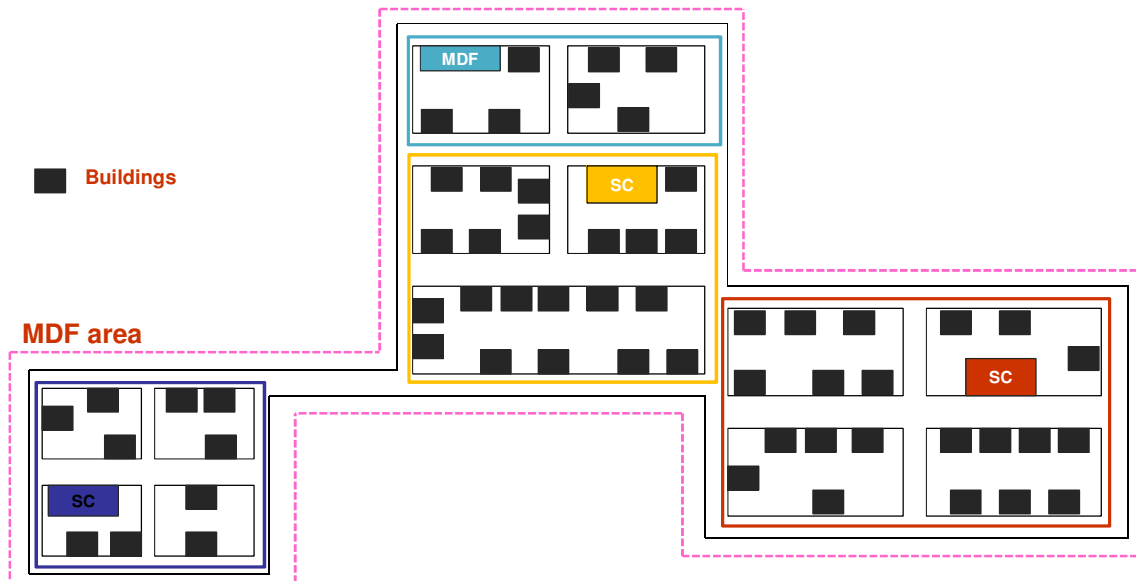

Source: TERA Consultants

In the fibre network, there are no SCs. All end-users are directly connected to the exchange (the ODF). However, intermediate flexibility points such as joints are modelled.

1.5.2.2 Network deployment at street level

Having determined the MDF and the SC coverage areas, it is possible to compute the cost efficient path connecting each end-user to a MDF. As described in the Model Reference Paper, this is based on the shortest path algorithm.

Two sets of paths therefore have to be computed to model the copper network:

- The shortest path from each building to its parent SC; and
- The shortest path from each SC to its parent MDF.

One set of paths has to be computed to model the fibre network which is the shortest path from each building to its parent ODF.

Figure 5 - Shortest path from SC to buildings

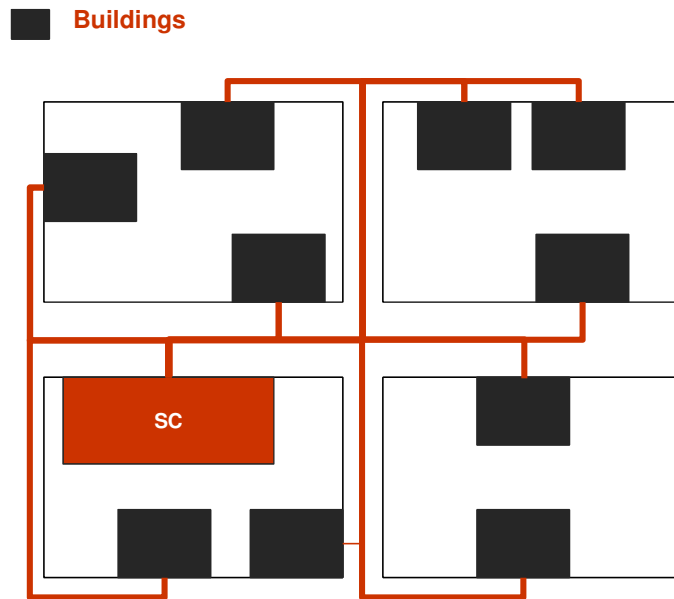

Source: TERA Consultants

Having computed all the shortest paths required, it is possible to compute the demand at the section level (a segment of road between two consecutive intersections).

The demand at the section level is made of:

- The demand of the current section, i.e. all the buildings located on this section; and
- The demand of the rear area of the section, i.e. all the buildings for which the shortest path to the SC or the MDF goes through the section.

Figure 6 - Computation of the local demand

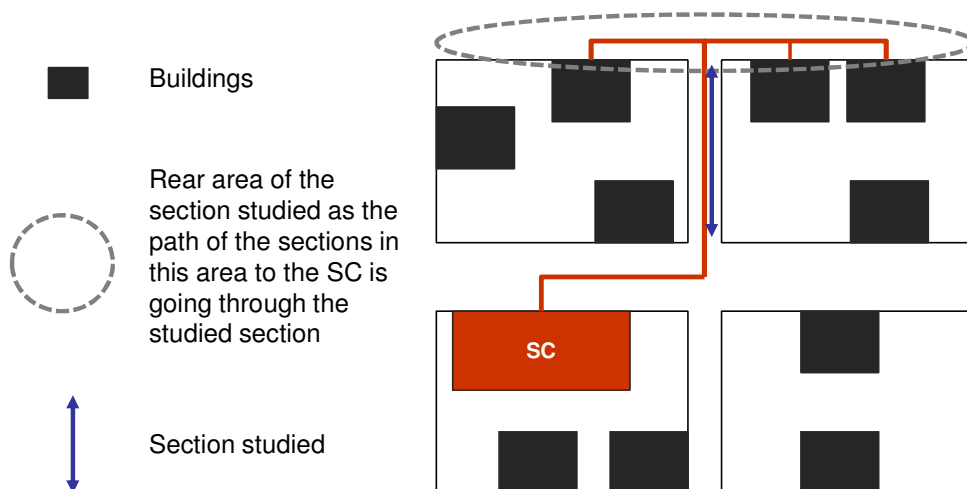

Source: TERA Consultants

In the above figure, the studied section has no local demand but has three buildings in its rear area: the distribution cable passing through this section must be dimensioned for those three buildings.

Furthermore, in the copper network, an additional feeder cable may be added if the connection between the SC and the MDF goes through the section.

The dimensioning of the access network at the section level consists of computing the number of assets required to meet the local demand, given engineering rules and a catalogue of assets.

1.5.3 Full network

The full network or the network at the exchange area level is dimensioned aggregating the number of assets computed at the section level. This allows the compilation of the network inventory.

This step ends the network dimensioning phase.

1.5.4 Current asset prices

The first step of the network costing is to derive the current unit cost, from all the unit costs applied, price trends and relevant mark-ups that capture all the required costs.

The current unit costs come in most cases from Chorus data collection or are otherwise inferred from benchmarks with other countries.

1.5.5 Capex

The total investment is based on the inventory of assets and the assets' current unit costs. It is obtained by multiplying the network inventory by the current asset prices.

1.5.6 Depreciation

The network yearly cost is obtained by applying the asset-specific depreciation formula to the network capex, which depends on

- Asset lives;
- Prices trends;
- The tax depreciation rates;
- The corporate tax rate;
- The post-tax nominal weighted average cost of capital (WACC).

1.5.7 Opex calculation

The opex estimates are derived from the Opex model.

The total yearly cost is obtained by summing the network yearly cost and the opex, including the non-network costs.

This step ends the network costing phase.

1.5.8 Network cost allocation

The network cost allocation is used to build the different prices that are based on the access network cost model.

The cost per line is the result of dividing the UCLL yearly costs and specific costs (e.g. wholesale costs) by the total number of active lines.

1.6 Core network modelling approach

The UBA price is the sum of the UCLL price and of UBA additional costs. In this paper, the scope of the network corresponding to the UBA additional costs is called the “Core UBA”.

In line with criterion 32 of the Model Reference Paper, the scope of the core network model covers the provision of the core (active) part of the UBA service and the dimensioning of all elements involved in this service as shown in the figure below. The passive part (local loop) is dimensioned and cost in the access network cost model.

Figure 7 - Core network model scope

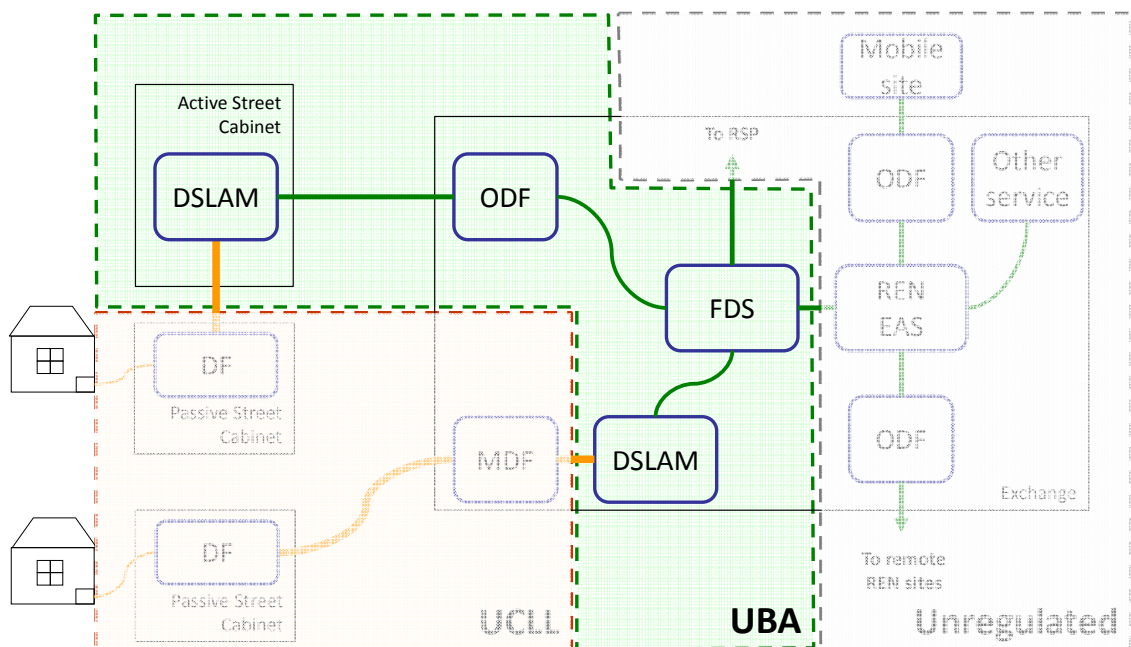

Source: TERA Consultants

The modelling is based on the modified scorched node approach described in §1.2. The demand is calculated at each existing node of the network. The network assets are dimensioned in order to fulfil this demand and provide the UBA service.

The UBA service consists of providing to RSPs (Retail Service Providers) a service starting from the network termination point (the ETP (external termination point) in the copper network) to an aggregation port located on a FDS (the port is not part of the monthly rental charge). It corresponds therefore to the combination of the UCLL service and the core UBA service as illustrated in the figure below:

Figure 8 - Core network model scope

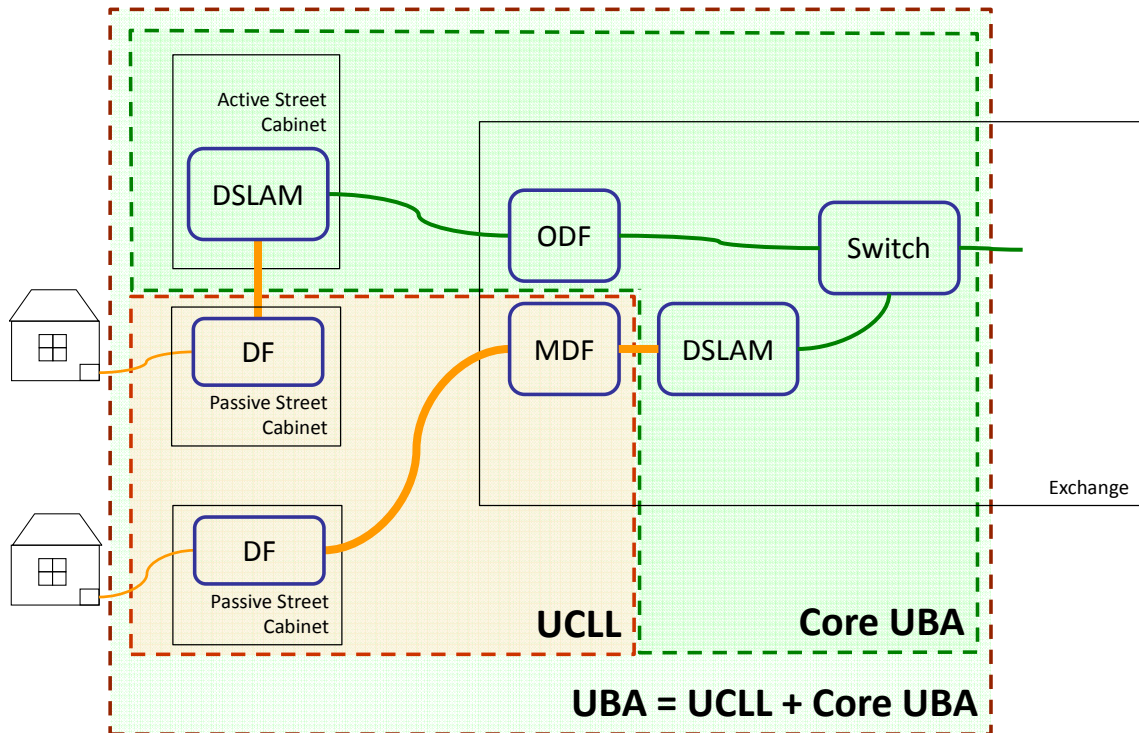

Source: TERA Consultants

However it has to be noted that the UCLL network may be used for other services than UBA, and therefore the UCLL network has more active lines than UBA customers. The economies of scale are therefore different between the two services.

2 Opex model

This section aims at describing the Opex cost model.

2.1 Opex data

The Opex model is based on Chorus' 2013/2014 accounts.

In order to forecast the opex for year 2015 and the subsequent years within its regulatory period, costs are divided into two main categories: labour related opex and non-labour related opex.

Labour related opex will evolve in the future with the wages. As a consequence, the labour related opex forecasts will be performed based on the labour cost index (LCI). The non-labour related opex are very difficult to forecast as they highly depend on the mix of expenditures (natural disease recovery, preventive maintenance on active equipment...) that is performed for a given year. For these different types of activities, price evolution is very different so assessing whether non-labour related opex will go up or down is very complex. As consequence, non-labour related opex will be considered as constant in the years to come.

2.2 Network expenses

2.2.1 Electricity and buildings expenses

All expenses related either to electricity or buildings costs are treated independently to derive a cost per kWh and a cost per m² that can be directly used in the TSLRIC models.

Hence, electricity and network building expenses are not included in the opex amount. These are assessed bottom-up in the Capex model as the demand (kWh requirement of each asset) is assessed in this model. Network building expenses aggregate together cost of rented sites, owned sites and associated property maintenance costs. These are assessed bottom-up in the Capex model as the demand (Floor space requirement of each asset) is assessed in this model.

2.2.2 Other expenses

Chorus' expenses are divided into several categories: labour costs, maintenance costs (mainly contractors' costs), IT costs, the cost of rents and taxes, the cost of electricity and buildings and some other costs. The different costs involved in network expenses are either related to specific equipment used for the UCLL and the UBA services or related to several assets at the same time. Therefore, each cost is allocated between the different equipment/services.

Allocation keys have to be consistent with the dimensioning driver in accordance with the capacity-based allocation approach (see criterion 54 of the Model Reference Paper). Thus, several allocation keys have to be computed. For example, maintenance

costs related to air-conditioning have to be allocated to active equipment such as DSLAMs and the different levels of EAS (Ethernet Aggregation Switch). Some allocation keys are based on data from the network cost models (access network cost model and core network cost model). Others can be based on allocation of other costs: for example, labour costs related to maintenance costs are allocated with an allocation key based on the maintenance allocation.

Once all network costs are allocated to the different equipment or directly to UBA or UCLL, a total amount related to both services is calculated.

2.3 Non-network expenses

Non-network expenses include headquarters labour, building, IT and electricity costs, insurance, consultants and miscellaneous others costs.

2.3.1 Type of costs

Two types of costs are categorised as non-network costs: non-network expenses provided by Chorus and network expenses that cannot be distributed among the different assets or services (see Model Documentation for model details).

2.3.2 Approach

The non-network common costs incurred by the operator have to be considered.

Two approaches can be used:

- building a “non-network cost mark-up”;
- using the non-network cost total amount in the model (after an allocation step).

The first approach consists in calculating the total amount of non-network costs from the accounting data and then dividing it by the total network cost from the account (annual capex + opex). It provides a non-network cost mark-up (%) that can be applied to the capex and opex calculated by the TSLRIC models. In Chorus’ case, costs that are modelled are likely to be higher than accounting costs (e.g. as accounts include fully depreciated assets). Hence, if the mark-up is applied on this amount, it will lead to a higher non-network cost than the existing one.

The second approach is to use the total amount of non-network costs from the accounting data in absolute value. With this approach, these costs need to be allocated between all the different services (both within and without the scope of the model). This allocation should ideally be based on the accounting costs with the use of regulatory accounts. However, this breakdown of cost per service is not available in Chorus annual report. But the revenue breakdown per service is available.

The second approach has been implemented. These costs are then allocated based on revenues.

2.3.3 Allocation of non-network costs between regulated and unregulated services

Non-network costs have to be allocated between all Chorus' services (regulated and unregulated services) whether they are modelled in the bottom-up models or not.

In line with the EPMU principle, this allocation should be based on accounting costs with the used of regulatory accounts. This breakdown of cost per service is not available in Chorus' annual report, but the revenue breakdown per service is available. Hence, this revenue data will be used as a proxy (for the cost data required to apply EPMU) to calculate the amount of non-network costs included and allocated to regulated services.

3 Geospatial

This section describes the geospatial data and the offline calculations that feed the access network cost model.

3.1 Reference files

There are two different types of geospatial inputs that are used:

- Data regarding New Zealand such as the road network and the location of the buildings; and
- Network data allowing modelling of a modified scorched node network such as the position of the exchanges, of the cabinets or the boundaries or the coverage areas of the exchanges.

The files that have been used in the geospatial work are referenced in the following table:

Table 1 – Geospatial reference files

File reference	Content	Usage
Corelogic Terrabase road and address database	Road and rail network, address points, and address categories	The address points were used as an estimate of the location of buildings. The road network was used to derive the theoretical network to connect the buildings to the exchange and street cabinets. The road classification and number of lanes was used to estimate the distance of an address from the road edge.
Landcare Research New Zealand Ltd, Land Resource Information System (LRIS) spatial data layers	Rock lithology	Input into trenching cost estimates.
Statistic NZ 2013 Census Data	2013 Meshblock and Census Data	Gross checks on Terrabase residential address coverage.
CERA – Red Zones	Areas zoned red where earthquake damaged land is unlikely it can be rebuilt on for a prolonged period	Identification of properties to be removed from model.

File reference	Content	Usage
Land Information New Zealand (LINZ) Survey Parcels	Survey Parcels, Legal Road Centrelines	Determine legal width (boundary to boundary) of roads. Determine distance of buildings to road frontage. Used as reference when adjusting exchange boundaries.
Building footprints	Building footprints for Auckland City, Christchurch City, Kapiti District, Porirua City, Tauranga City, and Wellington City councils, The data was either downloaded directly or used via an open web service	Used to determine the distance between a building and the road frontage. Used in conjunction with the Corelogic address database to estimate the distance from a building to the road frontage where the building footprint was not available.
Chorus Data	Exchange sites and boundaries, cabinet locations, cable paths	Used in coverage and shortest path calculations.
Vodafone RBI Sites and Coverage	Name and coordinate of existing and proposed sites and coverage of final (2019) RBI coverage	Used to determine FWA coverage.

Source: The Commission

3.2 Issues with the geospatial data

3.2.1 Road network

There were very few issues encountered with the road network data from Corelogic NZ Ltd. Initially some time was spent confirming the ownership of roads that were shown in the dataset as being privately owned when in fact it was clear that the road was public. Similarly many roads, particularly in rural areas, were shown as being public when they were actually a shared private access road. This issue became moot part way through the analysis when it was decided to include all roads (both public and private) in the network model.

3.2.2 Notional exchanges

The original exchange data included exchange areas that included a notional exchange building – that is the exchange building no longer existed. In these cases the exchange area was merged with an adjoining exchange area. The adjoining exchange area that was chosen was based on exchange parent information provided by Chorus.

Figure 9 - Showing nominal exchanges WRU and WHV being merged with WGE

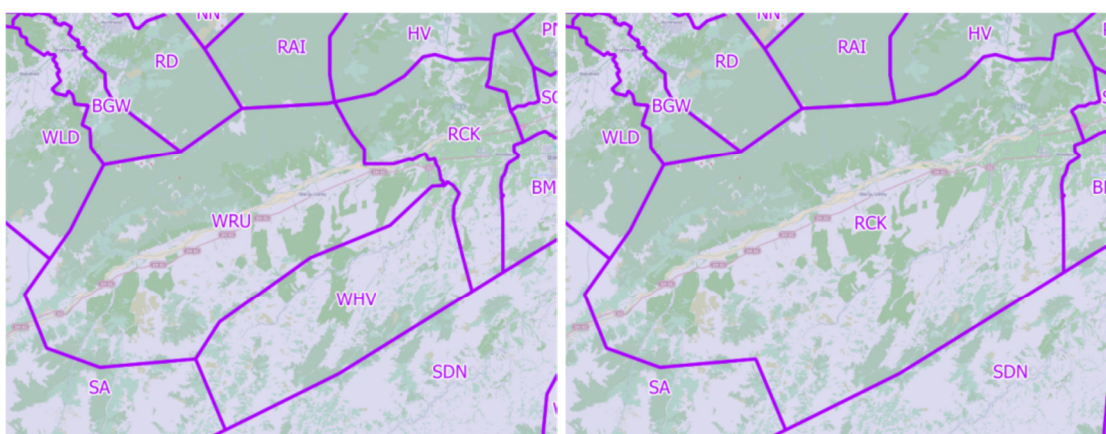

Source: The Commission

3.2.3 Holes and overlaps in the coverage of the exchange area definitions

The exchange area definition contained several overlaps and gaps between adjoining exchanges. These were fixed by running geospatial tools that filled the gaps and removed the overlaps.

In most cases the overlaps and gaps were either insignificant or were over an area with no or minimal road sections

Figure 10 - Showing gap in exchange area filled by extending exchange AK

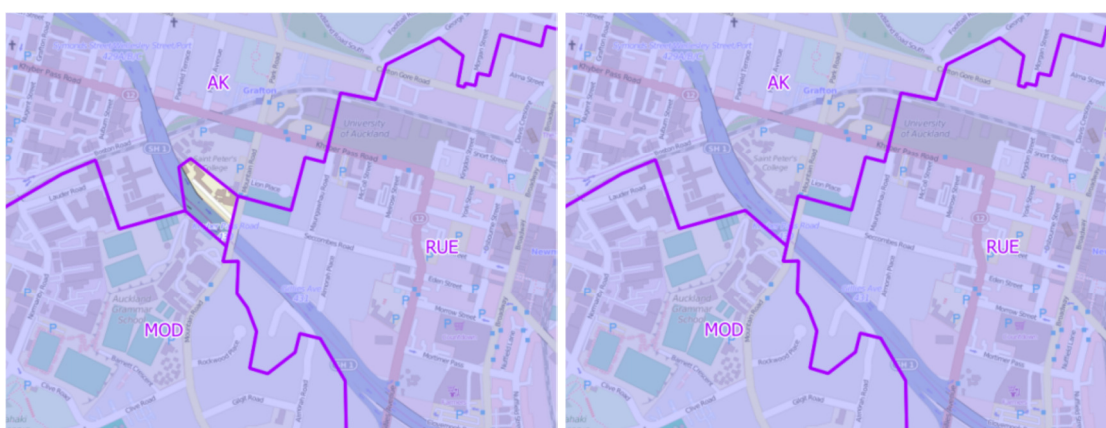

Source: The Commission

Figure 11 - Showing gap in exchange area filled by extending exchange MOD



Source: The Commission

Figure 12 - Showing overlap between exchanges EDG and WHK. After consultation with Chorus it was determined that the extent of the WHK exchange area was wrong.



Source: The Commission

Figure 13 - Showing gap in exchange area filled by extending exchange MTA



Source: The Commission

3.2.4 Exchange site not in exchange area

For modelling purposes the location of the exchange buildings must fall within the extent of the exchange boundary. This issue only occurred in one location (WGE) in which case the location of the exchange was shifted to coincide with the location of the nearest cabinet within the exchange area.

Figure 14 - Showing location of exchange (WGE) outside exchange boundary

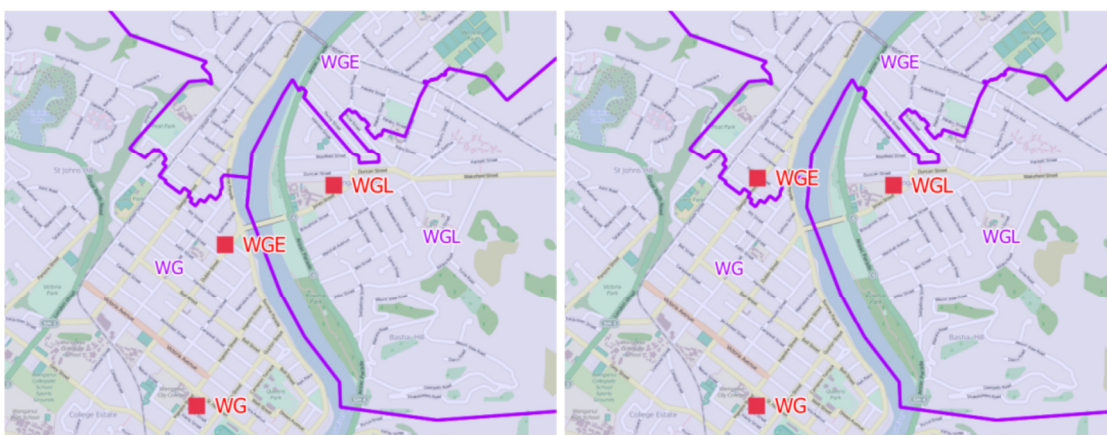

Source: The Commission

3.2.5 Multipart discontinuous exchanges

The extent of several exchange areas were composed on multiple discontinuous parts. Such areas were adjusted by retaining the portion of the exchange area that contained the exchange and merging the other portions of the exchange area with adjoining exchanges. The adjoining exchange was chosen based on a combination of the underlying road network and the proximity of the exchange within the adjoining exchange area.

Figure 15 - Showing parts of multipart exchange (BM) being merged with adjoining exchanges (SCK, RCK)

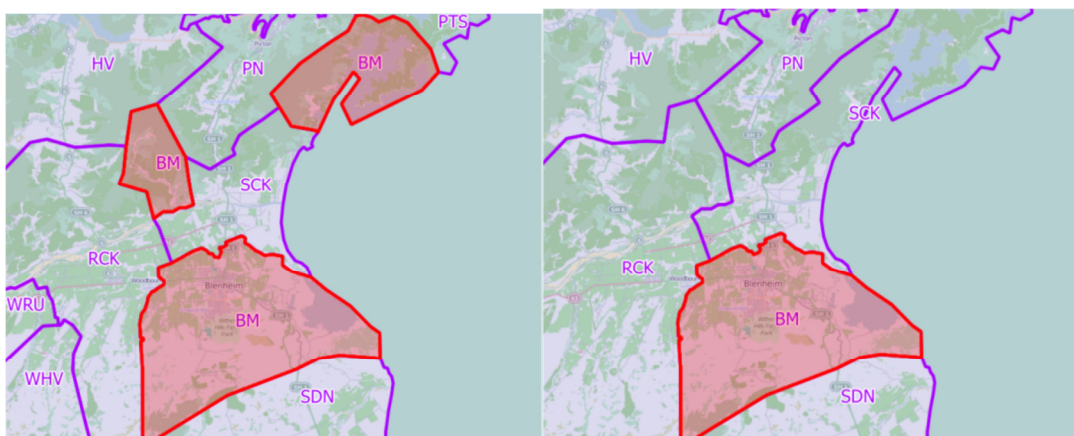

Source: The Commission

3.2.6 Exchange adjustments due to road network model

As the model is based on connectivity along the road network it was necessary to make adjustments to the extent of the exchange areas to enable the roads to connect back to the exchange following a path that is entirely within the exchange boundary. In some cases this was a very minor adjustment but in other cases it necessitated a significant change.

Figure 16 - Showing minor adjustment of boundary between LHT and PTN exchanges to accommodate all of Leighton Avenue



Source: The Commission

Figure 17 - Showing adjustment of boundary between DOB and NE exchanges to accommodate the sections of road, including around Blackball, north of the Grey River within the DOB exchange.

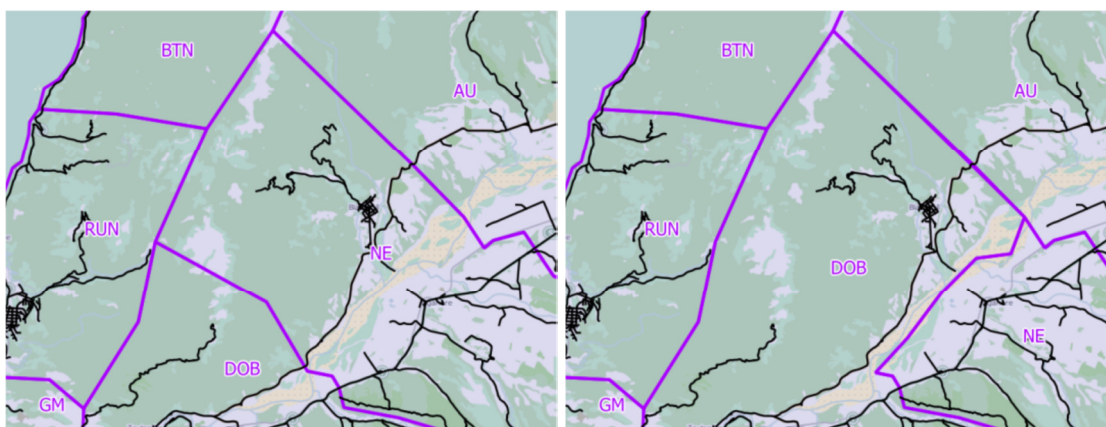

Source: The Commission

3.3 Copper network

As described in §4.2, the copper network is made of three parts:

- The “feeder” which is the link between the exchanges and the SC (active or passive);
- The link between the SC (active or passive) and the customers (exchanges are considered as a SC for the customers directly connected to the exchange). This link is made of the two following parts:
 - The “distribution” which is the part of the network between the SC and the CCT; and
 - The “lead-in” which is the part of the network between the CCT and the ETP.

The modelling of lead-in does not require deriving a set of paths as the dwellings are connected to a distribution point located on the same section. Two sets of paths are therefore required to connect all the dwellings.

Each path follows the road network and is the output of the shortest path algorithm restrained to an area:

- Restrained to the SC coverage area for the link between the SC and the customers; and
- Restrained to the MDF area for the feeder.

The computation of the shortest path algorithm is in line with the length-based optimisation as described in the Model Reference Paper.

3.3.1 SC coverage areas

The exchange coverage areas (or MDF area), the location of the exchanges and the location of the SC are known (data collected from Chorus).

Figure 18 – Starting point

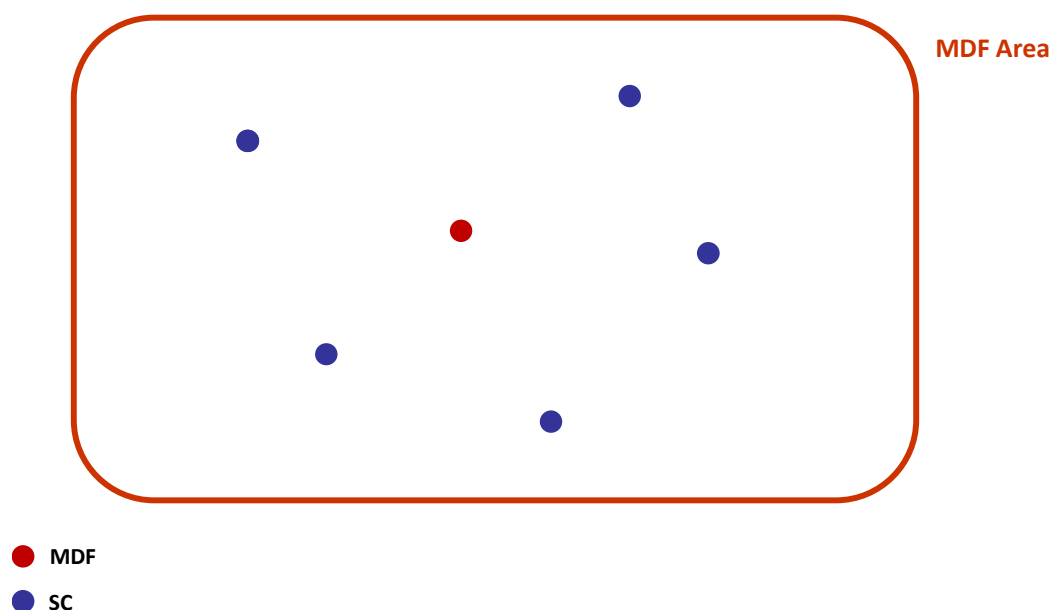

Source: TERA Consultants

The starting point of the modelling is therefore to determine the SC coverage areas, which has not been provided by Chorus.

All the customers have to be connected to a SC or to the exchange. The MDF therefore has its own SC coverage area. Each road is connected to the closest SC (or exchange for customers directly connected to the exchange). The distance between the road and the SC is the road distance and not the straightline distance as the network follows the roads.

The SC coverage areas have been determined by using the modified Voronoï's polygons:

- The boundaries of each polygon is computed so that the distance between any point inside any polygon and its centre is shorter than the distance to the centres of all other polygons;
- The distance used is the distance following the road network instead of the straightline distance.

Figure 19 – SC coverage areas

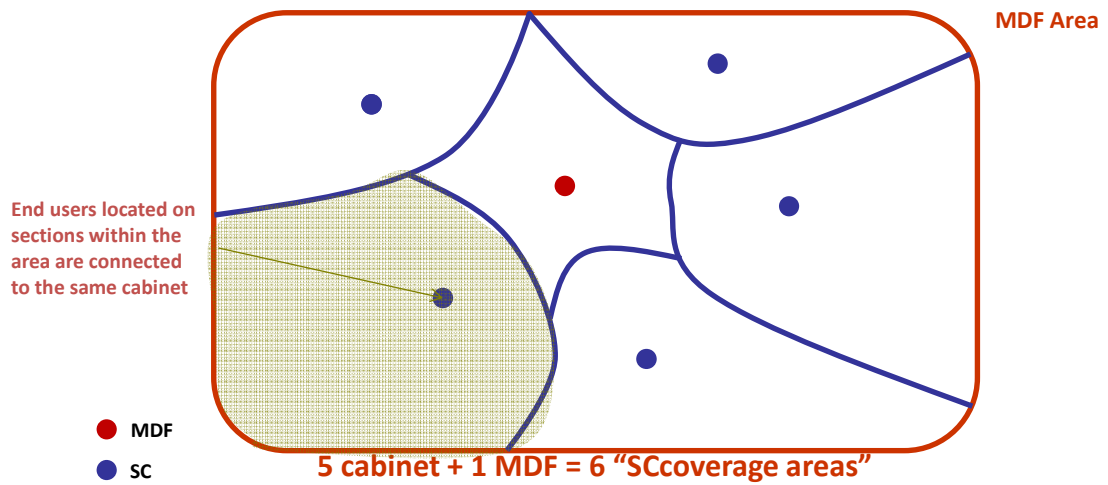

Source: TERA Consultants

All the customers located within the same SC coverage area are therefore connected to the same SC.

3.3.2 Distribution

The second step is to derive the distribution, i.e. the paths linking each customer to its parent SC.

Figure 20 – Distribution

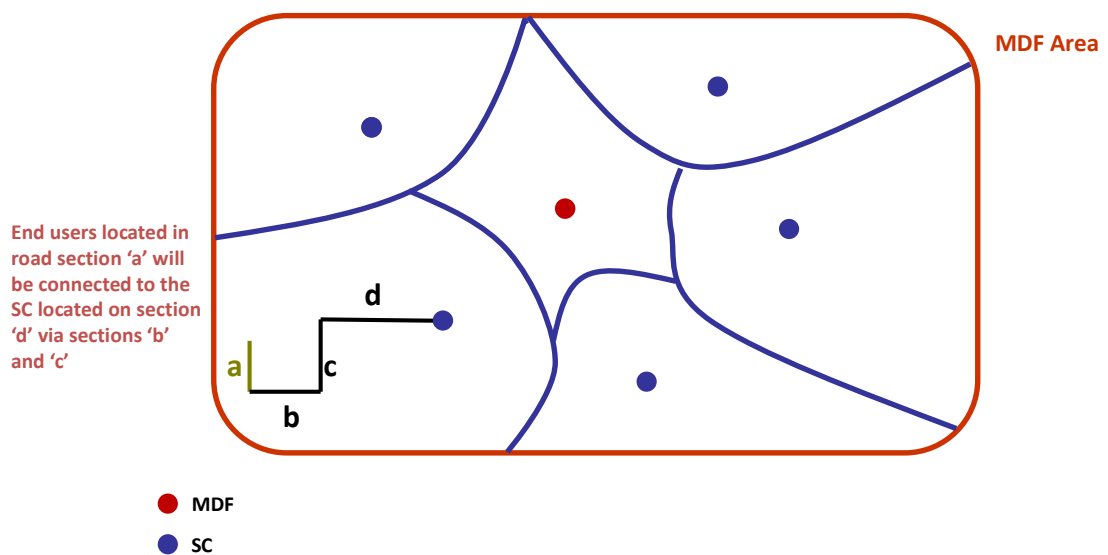

Source: TERA Consultants

The shortest path algorithm is applied to determine for each road its route linking it to its parent SC.

3.3.3 Feeder

The third step is to derive the feeder, i.e. the paths linking each SC to its parent exchange.

Figure 21 – Feeder

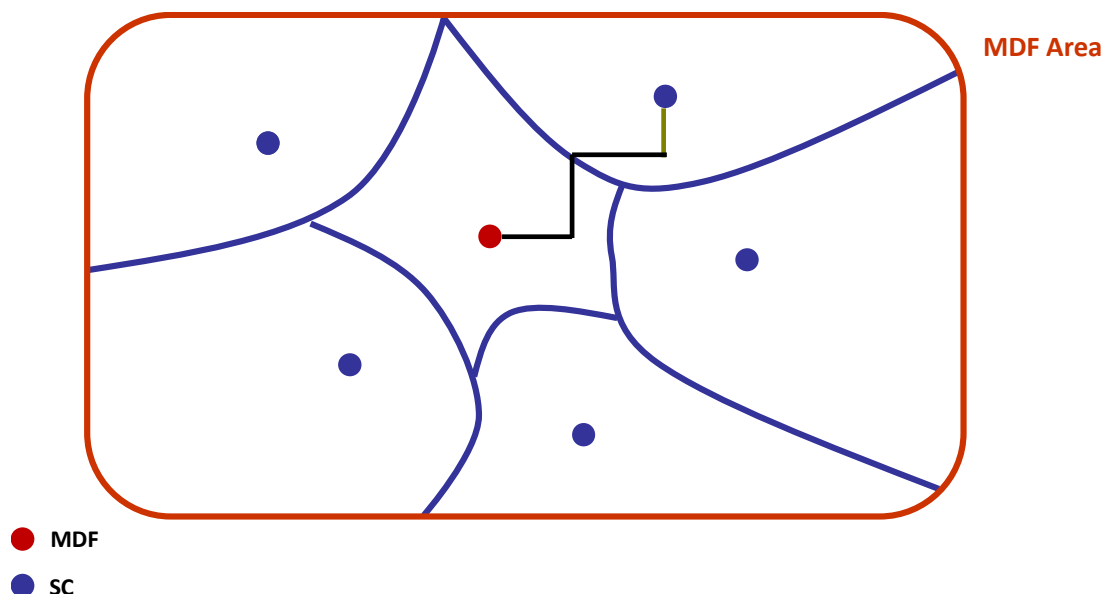

Source: TERA Consultants

The shortest path algorithm is applied to determine for each SC its route linking it to its parent exchange.

3.4 Fibre network

As described in §5.2, the fibre network is made of solely two parts

- The distribution which is the links between the exchanges and the FAT; and
- The lead-in which is the links FAT and the ETP.

Similarly to the modelling of the copper network, no set of paths is needed for the modelling of the lead-in. Only one set of paths is thus required to connect all customers to their parent exchange.

The shortest path algorithm is applied to determine for each customer its route linking it to its parent exchange.

3.5 Inter-exchanges links

The inter-exchange links are the fibre cables that are connecting exchanges together. There are two different types of links:

- The links between exchanges that both contain at least one switch. These links are not part of the scope of the core model. However, they have to be modelled in order to capture the relevant economies of scope; and
- The links between exchanges with at least one that does not contain a switch. These links are part of the UBA service and should be included in the modelling.

For each link, the starting point and the end point have been identified. The shortest path algorithm is applied to determine the path of the link.

The computation of the shortest path algorithm is in line with the length-based optimisation as described in criterion 26 and 27 in the Model Reference Paper.

3.6 DWDM links

In line with criterion 47 in the Model Reference Paper, the core network may contain DWDM links due to long distance. These long distance links have been identified from the full list of DWDM links provided by Chorus.

For each link, the starting point and the end point have been collected. The shortest path algorithm is applied to determine the path of the link.

3.7 Submarine links

In line with criterion 46 in the Model Reference Paper, the core network may contain submarine links connecting an island to the main land.

For each link, the starting point and the end point have been collected. The length of the link is its actual link.

3.8 Access part of the fibre leased lines³

The fibre leased lines⁴ are made of two parts:

- The core part that is shared with other services;
- The access part that is made of dedicated fibre cables.

The access part of the leased lines is interconnecting either:

- two sites together; or
- one site to a node of the network.

The cables used in the access part are sharing the same infrastructure (trenches, chambers, etc.) as the access network or the core network. There are therefore economies of scope that should be captured: the leased lines should bear a part of the infrastructure costs according to the space used.

Chorus has however been unable to provide any data regarding the access part of the fibre leased lines. If Chorus had provided geospatial information on where the access part of fibre leased lines, it could have been possible to identify the road sections where they are deployed and match these road sections with the road sections where

³ Copper leased lines are not provided using dedicated copper cables and therefore they are not discussed in here

⁴ Leased means any point to point link with a dedicated capacity regardless of the type of link (e.g. copper or fibre). It includes leased lines, fibre circuits, managed services etc.

the access and core networks are deployed. In order to overcome this absence of data, a macro-parameter has been defined that defines the level of cost that is allocated to the leased lines. This macro-parameter indicates the percentage of the length of access network which is shared with the access part of fibre leased lines. The value of this macro-parameter has been set so that the share of costs borne by the leased lines is consistent with what has been observed by TERA in other countries, where operators have provided detailed geospatial information on the access part of leased lines and therefore where it has been able to precisely assess the percentage of the access network which uses the same infrastructure as the access part of fibre leased lines.

3.9 Fixed wireless access

The fibre network scenario is a combination of a wired network (the fibre network) and a wireless (FWA) network).

The dimensioning of the FWA network requires:

- Determining the location of the base stations and their coverage which are the location and the coverage of Vodafone's sites part of the RBI program;
- Connecting each FWA site to the fibre network.

3.9.1 FWA coverage

As the location and coverage of Vodafone's sites are used to model the FWA network, the identification of the customers that will be served by a FWA connection instead of a fibre connection is carried out by identifying the sections located in the coverage areas provided by Vodafone. Capacity constraints of FWA have been taken into account to limit the coverage and are described in §6.2.

3.9.2 Connection of the FWA sites

In line with criterion 14 in the Model Reference Paper, each FWA site is connected to the closest exchange by a fibre cable. The sections located on the paths from an exchange to a FWA site are connected by the fibre cable even if they are located in the FWA coverage areas.

As described in §3.4, the fibre network is based on direct links between customers and the exchanges using the shortest path algorithm. There is thus no need to derive any extra path for linking the FWA sites to their parent exchange.

4 Equipping the copper access network

4.1 Demand for the copper access network

4.1.1 Actual demand

As described in the Model Reference Paper, the demand for the copper access network is Chorus' actual copper demand plus the LFC demand and the Chorus UFB demand.

4.1.2 Forecast demand

In line with criterion 22 in the Model Reference Paper, the demand is assumed to be stable.

4.2 Copper network

The architecture of the modelled local access copper network (see Figure 22 below) includes 3 levels of nodes:

- MDF;
- SC; and
- CCT.

CCTs are always located on the section of the lead-in building.

Figure 22 – Architecture of the local access copper network

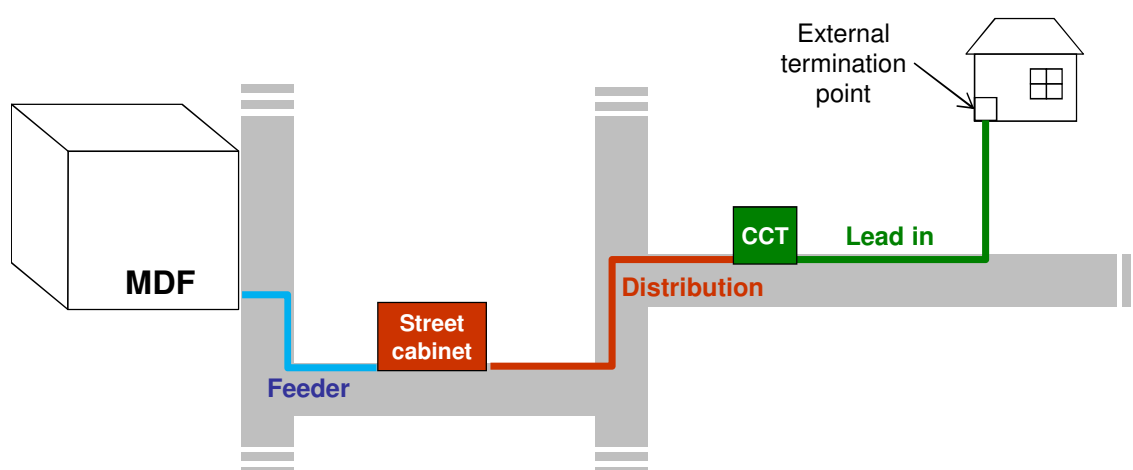

Source: TERA Consultants

Hence, there are three levels of networks:

- Feeder: from the Exchange to the street cabinet;
- Distribution: from the street cabinet to the CCT;
- Lead-in: from the CCT to the ETP at the foot of the building.

The feeder, distribution and lead-in cables are copper cables.

The MDF and street cabinets coverage areas are an input of the Microsoft Access component of the access network cost model, and the paths between MDF and street cabinets, as well as the path between street cabinets and sections, are based on the shortest path algorithm.

When the street cabinet contains active equipment, then the link between the MDF and the street cabinet is a fibre cable used to provide the SLU backhaul.

In such a case, there is no feeder in the local access network.

Figure 23 – Architecture of the local access network when the street cabinet is active

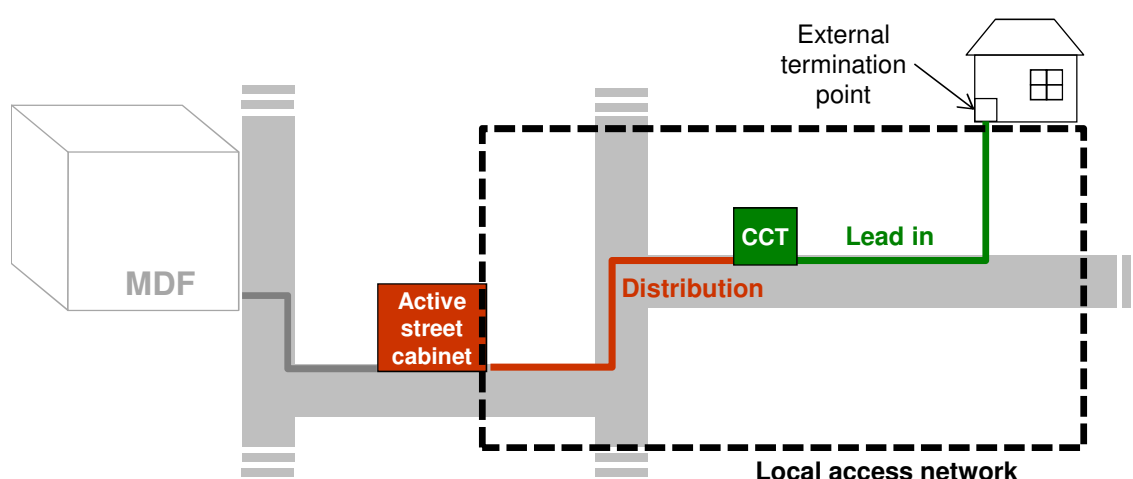

Source: TERA Consultants

As the CCT are located on the section of the buildings they serve, most of the “Lead-in” assets can be computed at the building level.

Furthermore, it should be noted that Chorus charges the end-user for the lead-in installation as part of the connection fee.

When the dwelling is beyond 100 meters (the non-standard lead-in), the lead-in is fully funded: the end-user is charged for all the costs incurred by Chorus.

Conversely, when the dwelling is a standard line, i.e. is within 100 meters to the road, the end-user pays a set fee (the connection fee). It is necessary to model the lead-in for such lines.

Therefore, the model includes two options:

- The non-standard lead-in can either be included in the model or excluded (and therefore be included or excluded from the total cost recovered by the prices). By default, the non-standard lead-in are included in the model;
- The revenues charges by Chorus can either be included in the model or excluded. By default, the revenues received by Chorus are excluded from the model.

Consequently, the model has the capability of distinguishing between standard and non-standard lead-in to reflect any differences in how the lead-ins are paid for. By default, all lead-ins are included in the model.

Figure 24 – Standard and non-standard lead-in

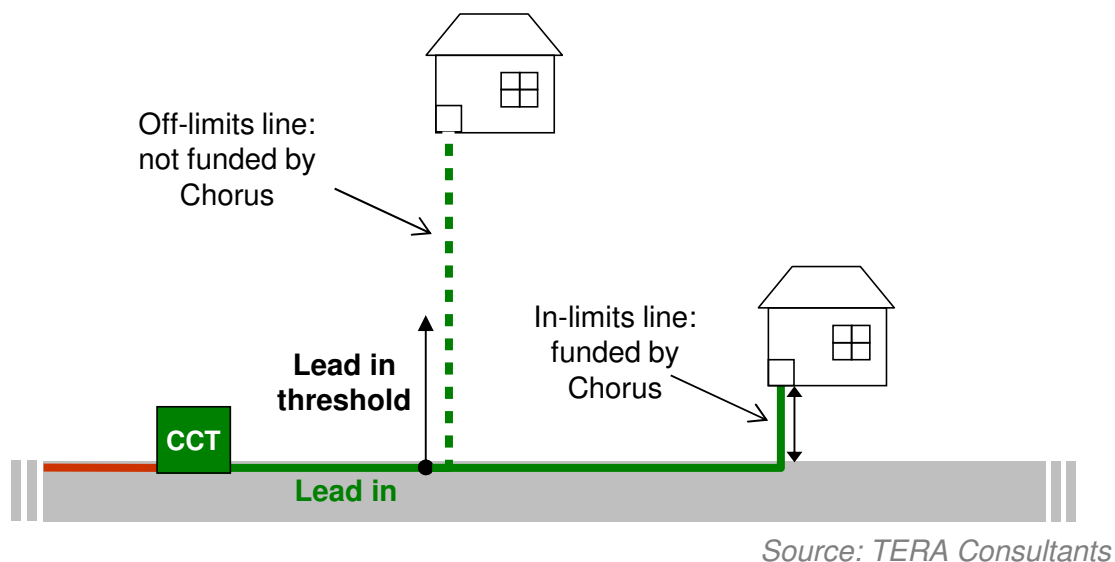

The dimensioning of the local access network is then made in two steps:

- Dimensioning at the building level;
- Dimensioning at the section level.

4.3 Network dimensioning

4.3.1 Section configuration

The side of the section with the majority of buildings is called the “major side”, and the opposite side the “minor side”.

When the access network is underground, the section can be trenched on the major side or on both sides of the section, according to the number of building on the minor side and the distance between buildings on the minor side.

The section is trenched on both sides when it is cost effective, i.e. when:

- Trenching the cross road at each building exceeds the length of a trench along the minor side plus a crossroad trench.

Figure 25 – Section configuration

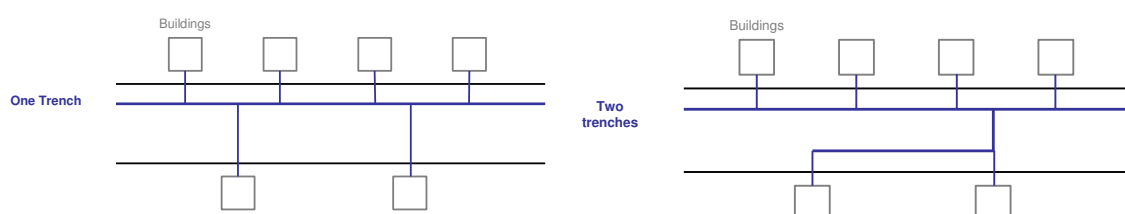

When the section is overhead, the cables and equipment are deployed only on the major side of the section.

4.3.2 Cables

4.3.2.1 Lead-in

TERA have used copper pairs' allocation rules. [] CNZRI:

- 2 pairs aerial copper cables when the lead-in level is overhead;
- 2 pairs underground copper cables when the lead-in level is underground.

The lead-in copper cable is deployed from the CCT to the ETP on the building.

When underground, the lead-in cable follows the section to the building's projection onto the road, then go to the building vertically.

When overhead, the lead-in cable goes in a straight line from the CCT to the building.

Figure 26 – Length of the lead-in cable

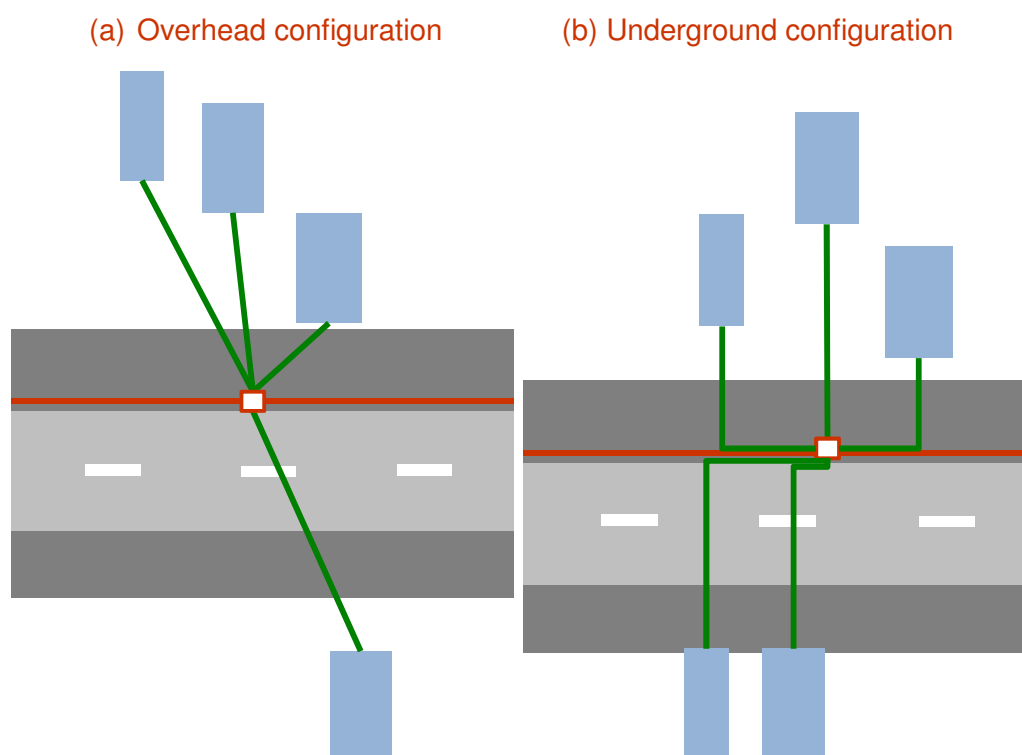

Source: TERA Consultants

The CCT are placed on the road according to three engineering rules:

- Maximum number of buildings lead-in per CCT;
- Maximum length between the building and the CCT;
- No more than one CCT per building.

The CCT are located uniformly along the section, on the segment from the first to the last building.

When the section is trenched twice, i.e. on each side of the street/road (as described in §4.3.1), the CCT are placed on each side of the section and dimensioned on each side of the section.

4.3.2.2 Distribution

The distribution cable is a copper cable dimensioned to fit the local distribution demand, i.e. to distribute:

- The dwellings on the minor side;
- The dwellings on the major side;
- The dwellings on the rear area of the section.

The distribution cable dimensioning is made following copper pairs allocation rules.

The rules may differ for single dwelling units and multi dwelling units, as well as for urban and rural dwellings.

Spare capacity is added at the distribution level.

Following roll-outs best practices, when the distribution demand exceeds the largest cable available (2,000 pairs in underground, 50 pairs in overhead), multiple 2,000-pairs (respectively 50 pairs) cables are deployed to meet the demand.

The distribution cable is deployed all along the section when the section has a distribution rear area, or only until the last building of the section when the section has no distribution rear area.

When the section is trenched twice, a distribution cable is deployed on the minor side to fit the minor side distribution demand.

4.3.2.3 Feeder

The feeder cable is the copper cable linking the MDF to the street cabinet. For each section, the feeder cable is dimensioned to feed the street cabinets whose path to the MDF goes through the section.

The feeder cable dimensioning is made following copper pairs allocation rules.

The rules may differ for single dwelling units and multi dwelling units, as well as for urban and rural dwellings.

No spare capacity is added at the feeder level.

When the feeder demand exceeds the largest cable available (2000 pairs in underground, 50 pairs in overhead), multiple 2000-pairs (respectively 50 pairs) cables are deployed to meet the demand.

The feeder cable is deployed all along the section.

4.3.3 Joints

4.3.3.1 Lead-in

There are no joints at the lead-in level.

4.3.3.2 Distribution

On the major side, joints are used according to the standard drum length of the copper cable used. When there is already equipment along the cable, joints are not necessary as the existing equipment can be also used as joints.

On the major side, joints can be replaced by the CCT, street cabinets and MDF.

On the minor side, joints can be replaced by the CCT.

If the section has a distribution rear area, then there is at least one joint at the intersection with the rear area section(s) (see below).

When there is a minor side trench, there is at least one joint at the intersection with major side (see below).

Figure 27 – Joints on the major and minor sides

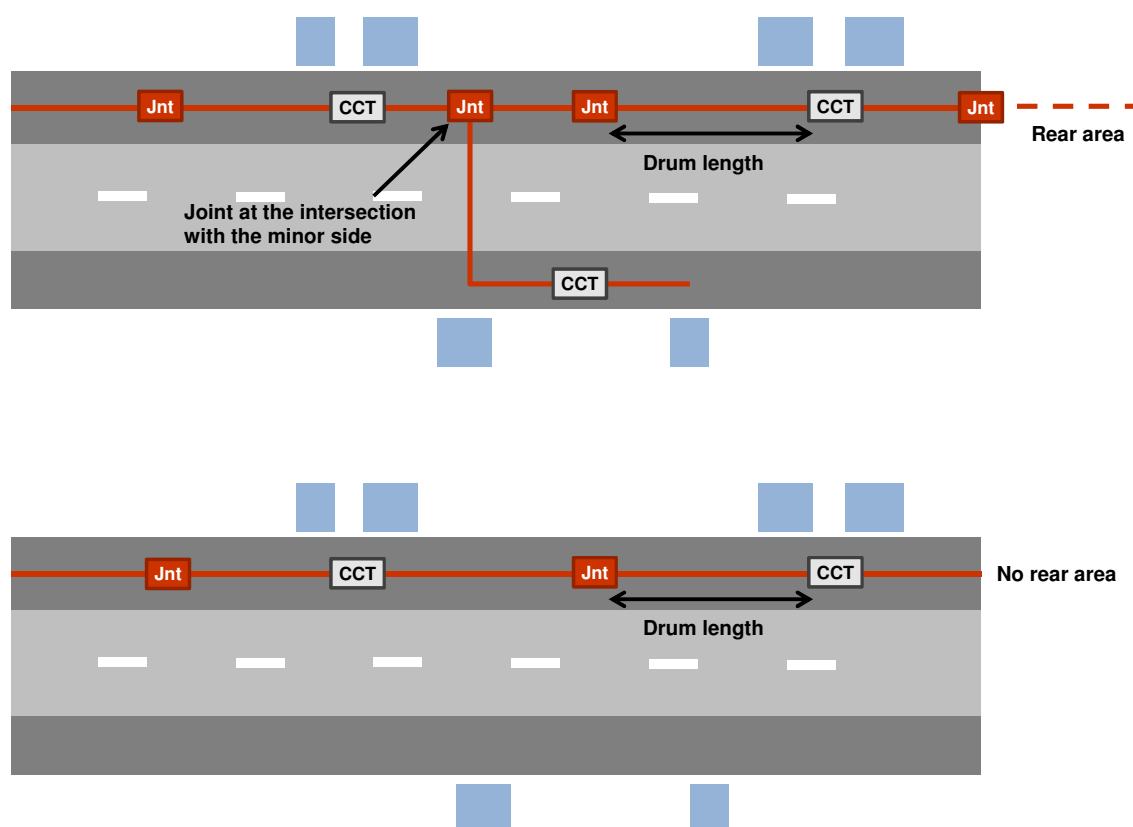

Source: TERA Consultants

4.3.3.3 Feeder

Joints are used according to the standard drum length of the copper cable used. Joints can be replaced by the existing equipment on the section, i.e. streets cabinets and MDF.

If the section has a feeder rear area, then there is at least one joint at the intersection with the rear area section(s).

4.3.4 Civil engineering

4.3.4.1 Aerial versus underground

The copper network is modelled twice: as an underground network, and as an overhead network.

The two resulting networks are then combined according to the underground/overhead mix in each exchange area.

The underground network is 100% underground.

The overhead network contains underground sections, when trenches are already dug for the core network. In such case, the lead-in level stays overhead and the distribution and feeder level are buried and follow the underground dimensioning rules (dimensioning of ducts, trenches, choice of cables).

4.3.4.2 Poles

In the overhead network, poles are located on the major side of the section only.

They are located according to the following rules:

- Maximum distance between poles;
- Cable overhead equipment (CCT, joints), that must be deployed on poles.

The number of poles for the distribution and feeder levels is estimated by the maximum equipment per cable for each level.

Poles are also deployed on the vertical part of the section, when the lead-in cable exceeds the maximum distance between poles.

Figure 28 – Location of poles

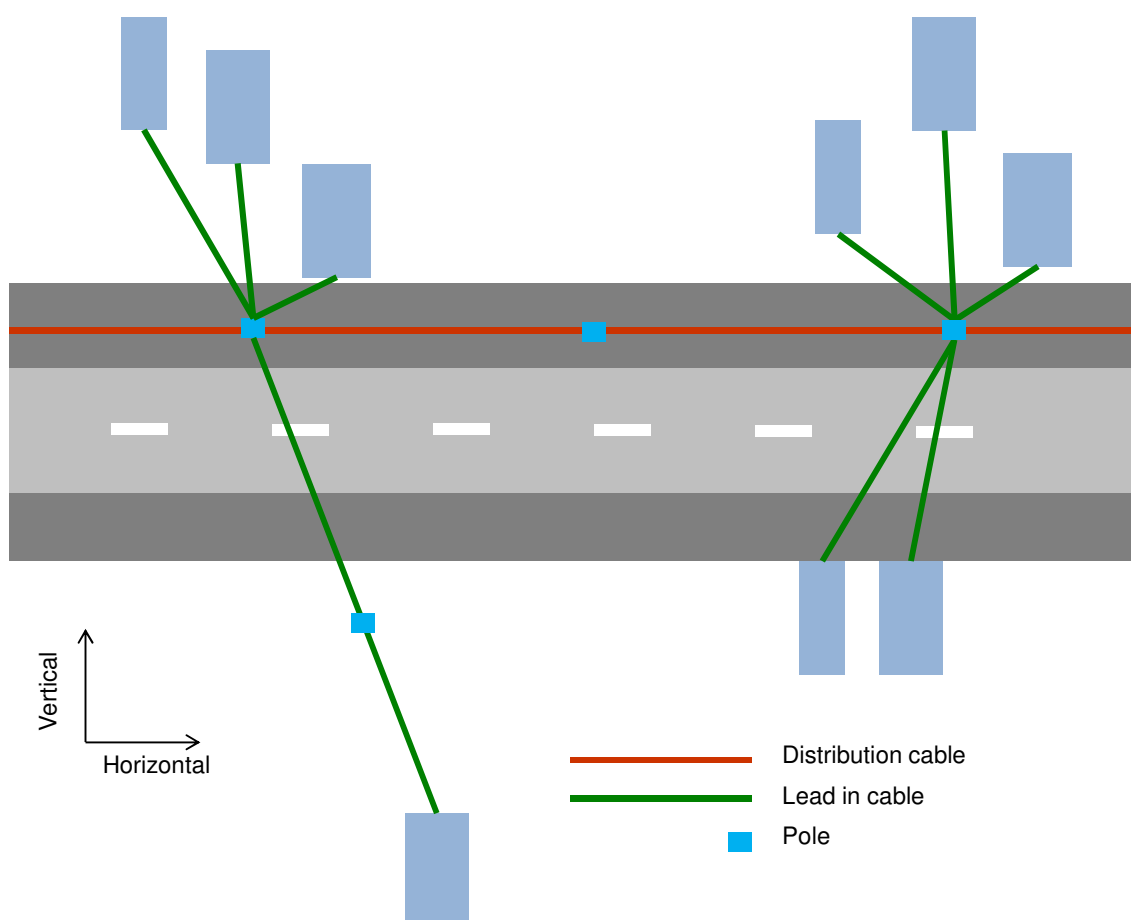

Source: TERA Consultants

4.3.4.3 Ducts

In the underground network, ducts run over the full length of cable of the section, from the lead-in cables to the core cables.

When the length of cables differ, e.g. when the distribution cable goes to the last building and the feeder cable goes to end of the section, the ducts run over the longer length of cable.

The cut surface of ducts provides an estimate of the size of the trench.

4.3.4.3.1 Lead-in vertical ducts

Each building has a dedicated 50 mm duct, which is deployed on the vertical part.

4.3.4.3.2 Lead-in, distribution and feeder

Lead-in, distribution and feeder share a 110 mm duct. When the cable surfaces exceed the duct useful surface, multiple ducts have to be used. The ducts are allocated following a capacity-based approach. As the number and size of cables is the driver of the duct dimensioning, ducts are allocated on the basis of cable surfaces.

The share of ducts that shall be allocated to lead-in is allocated to distribution.

4.3.4.3 FWA and core network

Each of the FWA and core cables is protected within a sub-duct.

The FWA, core DSLAM-to-Exchange, core Exchange-to-FDS and inter-FDS networks share one or more 110 mm ducts, on the basis of the surface of sub-ducts.

4.3.4.4 Trenches

4.3.4.4.1 Vertical trenches

Each building has a vertical dedicated trench (see diagram above for the definition of a vertical trench), whose size is measured by the number of 50 mm ducts along the trench, i.e. the number of 50 mm ducts dedicated to the building.

4.3.4.4.2 Horizontal trenches

When the section is trenched twice (as described in §4.3.1), there are three portions of trench with different sizes:

- The minor side trench;
- The road cross trench;
- The major side trench.

Figure 29 – Horizontal trenches

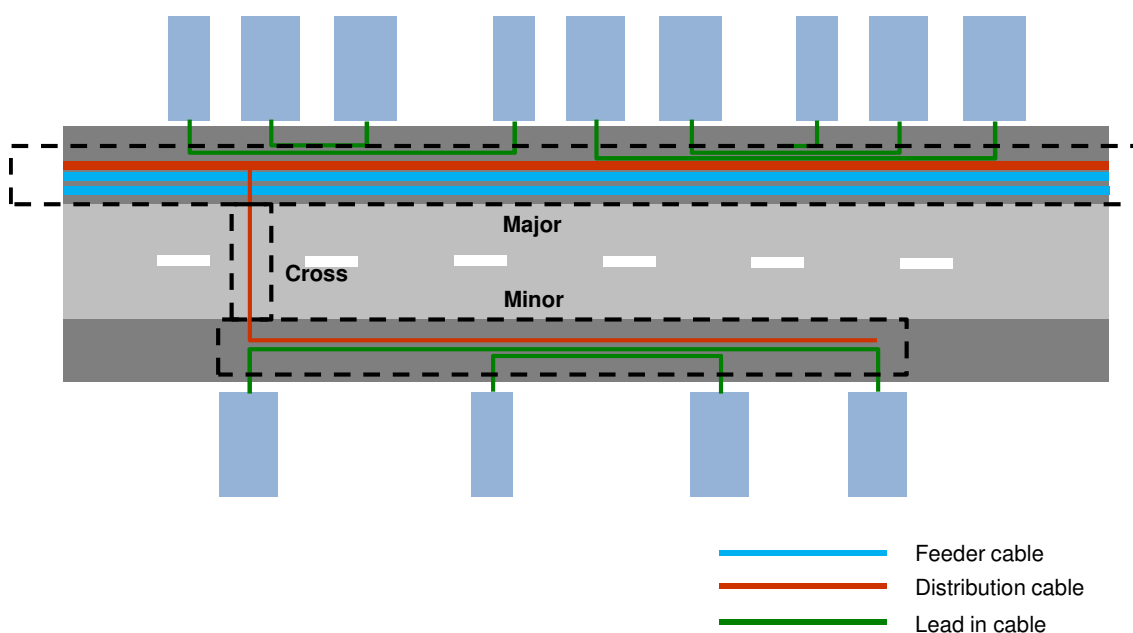

Source: TERA Consultants

The minor side trench runs along the buildings of the minor side. The minor side trench size is determined by the number of ducts shared by distribution and lead-in on the minor side. The need for ducts for lead-in is computed through an average.

The crossroad trench runs across the width of the road. The crossroad trench size is determined by the ducts needed for the distribution cables on the minor side.

The major side trench runs along the section or until the last building (as described in §4.3.4.3). Its size is determined by:

- The number of ducts for the access network (lead-in, distribution and feeder);
- The number of ducts for FWA and core;

Trench costs are allocated following a capacity-based allocation approach. As the capacity of a trench is driven by the number of ducts buried, the trenches are allocated on the basis of the surface of ducts. For instance, the allocation key for distribution is the composed ratio:

$$\frac{Surface_{cable}^{distr}}{Surface_{cable}^{lead\ in} + Surface_{cable}^{distr} + Surface_{cable}^{feeder}} * \frac{Surface_{ducts}^{access}}{Surface_{ducts}^{access} + Surface_{ducts}^{core}}$$

The need of ducts for lead-in is computed using the average number of dwellings per building over the section.

The costing of trenches is based on their size and the terrain and soil types.

4.3.4.5 Chambers

A chamber is either a manhole, a handhole or a pithole. It is an underground box where joints are installed and can be easily accessed.

The number of chambers is determined on the basis of the following rules:

- The maximum distance between chambers, due to pulling in tension limits;
- The number of underground equipment that should be freely accessible (joints, CCT).

The chambers are allocated following the same allocation keys as the trenches.

4.4 Civil engineering sharing

4.4.1 Civil engineering sharing with the core network

Underground infrastructures are shared with the core network. The access network cost model provides as an output the allocated assets for each network level, including for the core network (see above).

4.4.2 Civil engineering sharing with the access part of leased lines

As explained in §3.8, the underground infrastructure is shared with the leased lines network, resulting in cost reduction. This cost reduction is implemented through a macro-parameter applying to underground infrastructure investment.

4.4.3 Civil engineering sharing with utilities

Underground and overhead infrastructures might be shared or rented to utility networks, leading to cost reduction, according to data from the Commission.

Such infrastructure sharing is performed through four parameters when assessing the local access network investment:

Table 2 – Parameters setting the percentage of shared infrastructure

Parameter	Value
Percentage of shared underground infrastructure	0%
Percentage of shared overhead infrastructure	50%

Source: TERA Consultants

Table 3 – Parameters setting the percentage of cost adjustment when infrastructure is shared

Parameter	Percentage of adjustment
Cost reduction due to shared underground infrastructure	0%
Cost reduction due to shared overhead infrastructure	100%

Source: TERA Consultants

As half of the poles used by Chorus are rented to other utilities, it is assumed the overall cost reduction stemming from pole sharing is 50%.

No such sharing exists in relation to duct or trench infrastructure.

5 Equipping the fibre access network

The fibre access network dimensioning follows similar rules, if not identical rules, to the copper access network dimensioning.

Thus, many references are made to §4.

5.1 Demand for the fibre access network

5.1.1 Current demand

In line with criterion 19, 20 and 21 in the Model Reference Paper, the demand for the access network is Chorus' actual copper demand plus the LFC demand and the Chorus UFB demand.

5.1.2 Forecast demand

In line with criterion 22 in the Model Reference Paper, the demand is assumed to be stable

5.2 Fibre network

In line with criterion 8 in the Model Reference Paper, the access fibre network is a point-to-point fibre network (see Figure 30) and includes 2 levels of nodes:

- ODF; and
- FAT.

FATs are always located on the section of the led in building.

Figure 30 – Architecture of the local access fibre network

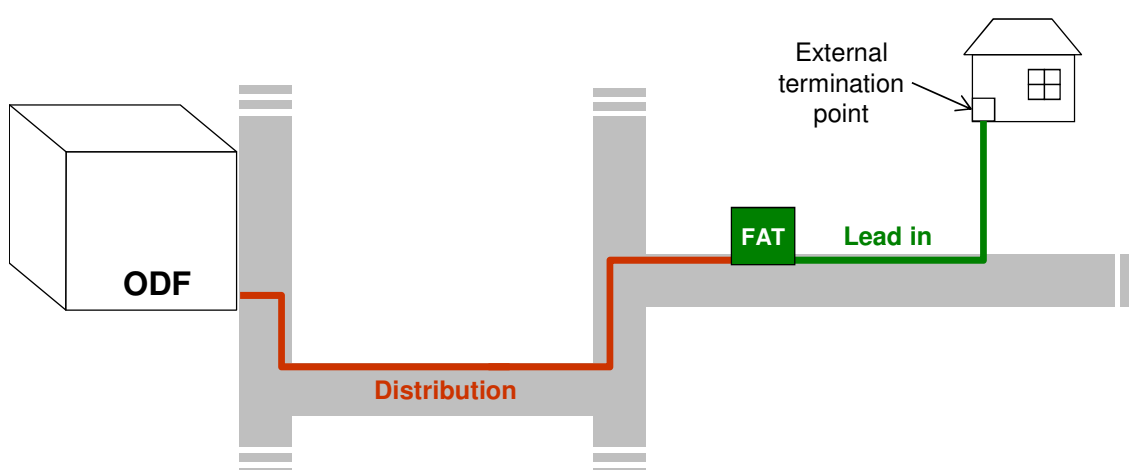

Source: TERA Consultants

Hence two levels of networks:

- Distribution: from the Exchange to the FAT
- Lead-in: from the FAT to the ETP at the foot of the building.

The distribution and lead-in cables are fibre cables.

The MDF coverage areas are an input of the Microsoft Access component of the access network cost model, and the paths between MDF and sections are determined based on the shortest path algorithm.

As the FAT are located on the section of the buildings they lead-in, most of the lead-in assets can be computed at the building level.

When a section is in the FWA coverage area, the section is not served by the fibre access network. Sections that are along the backhaul cables (FWA cables, core cables) are withdrawn from the FWA coverage areas, as underground infrastructures are already deployed.

Furthermore, as in the copper network, a “lead-in threshold” can be used in the fibre network to limit the costs of lead-in to the scope Chorus actually incurs (see §4.2).

The dimensioning of the local access network is then made in two steps:

- Dimensioning at the building level;
- Dimensioning at the section level.

5.3 Network dimensioning

5.3.1 Section configuration

The section configuration follows the same rule in the fibre and copper networks (see §4.3.1).

5.3.2 Cables

5.3.2.1 Lead-in

Following Chorus lead-in fibre allocation rules and the fibre catalogue, the lead-in fibre cables are:

- 2 fibres aerial cables when the lead-in level is overhead;
- 2 fibres underground cables when the lead-in level is underground.

The lead-in fibre cable is deployed from the FAT to the ETP in the same way the lead-in copper cable is deployed from the CCT to the ETP.

The dimensioning and location of FAT follows similar rules to CCT, possibly with different parameters in some instances.

5.3.2.2 Distribution

As in the copper network, the distribution cable is a fibre cable dimensioned to fit the local distribution demand: dwellings on the minor and major sides and on the rear area of the section.

The distribution cable dimensioning is made following fibre allocation rules, which are identical for all dwellings, single dwelling units and multi dwelling units, urban and rural

dwellings: one fibre per dwelling at the distribution level, in accordance with observed best practices (Chorus has not provided any engineering rule for this).

When the distribution demand exceeds the largest cable available (312F for underground and overhead), multiple 312F cables are deployed to fit the demand.

As in the copper network, the distribution cable is deployed all along the section when the section has a distribution rear area, or only until the last building of the section when the section has no distribution rear area.

When the section is trenched twice, a distribution cable is deployed on the minor side to fit the minor side distribution demand.

5.3.3 Joints

5.3.3.1 Lead-in

As in the copper network, there are no joints at the lead-in level.

5.3.3.2 Distribution

The dimensioning of joints follows the same rules in the copper and fibre networks (see §4.3.3.2), replacing CCT by FAT and using fibre cable drums, which are significantly longer than copper cable drums.

5.3.4 Civil engineering

5.3.4.1 Aerial versus underground

As for the copper network, the fibre network is modelled twice; as an underground network, and as an overhead network. Underground/overhead combination and overhead design rules when core network shares the section are identical in the copper and the fibre networks (cf. 4.3.4.1).

5.3.4.2 Poles

Pole dimensioning and allocation follow the same rules as for the copper network (see §4.3.4.2).

5.3.4.3 Ducts

Duct length and dimensioning follow the same rules in the copper and in the fibre networks (see §4.3.4.3), differing slightly on:

- Duct dimensioning and allocations are always based on sub-duct surface rather than cable surface, as all fibre cables are protected within sub-ducts;
- As fibre cables are protected in sub-ducts, the access network cost model also dimensions the length of sub-ducts for each network level;
- There is no feeder level in the fibre network, hence one set of ducts is dedicated to distribution instead of being shared among distribution and feeder.

5.3.4.4 Trenches

Trench configuration, dimensioning and allocation follow the same rules in the copper and in the fibre networks (see §4.3.4.4), with the slight difference that there is neither feeder level nor core DSLAM-to-Exchange in the fibre network, hence no trench is allocated to these levels.

5.3.4.5 Chambers

Chamber dimensioning and allocation follow the same rules in the copper and in the fibre networks (cf. 4.3.4.5).

5.4 Civil engineering sharing

Sharing with other infrastructures and asset re-use follow the same rules in the copper and fibre networks (see §4.4).

6 Equipping the fixed wireless access network

6.1 Demand for the fixed wireless access network

6.1.1 Current demand

The demand is based on the active customers located within the Vodafone actual RBI coverage areas, the throughput capacity of the FWA sites at busy hour and the customers' peak throughputs at busy hour.

6.1.2 Forecast demand

In line with criterion 22 in the Model Reference Paper, it is assumed the demand is stable.

6.2 Fixed wireless access network

The fixed wireless access network consists of FWA base stations covering dwellings within their coverage areas, and fibre cables linking the FWA base stations to their nearest ODF.

FWA base stations consist each of three sectors. As with any mobile base station, FWA base stations have a limited capacity. Thus, only the most expensive "lines" within their coverage areas are covered by FWA, the less expensive being served by fibre.

First, those sections crossed by the FWA backhaul cable or by a core cable are designated to be served by the fibre access network, as the cost of serving them is lower since the infrastructure e.g. trenches can be shared. Thus, those sections are withdrawn from eligibility for FWA coverage (see Figure 31).

Secondly, a proxy of the cost per line is used to assess which of the remaining eligible sections are the most expensive within the coverage area. For each section:

$$\text{Cost per line proxy} = \frac{\text{Distance to the exchange}}{\text{Number of lines}}$$

Where the number of lines takes into account all the lines passing through the section i.e. the lines corresponding to the dwellings of the section and to the dwellings located on the rear area of the section.

Then, for each FWA base station, the sections still eligible for FWA coverage are ranked from the most expensive to the least expensive. The most expensive dwellings are then designated as eligible for FWA coverage.

The number of eligible dwellings covered by a base station is obtained by dividing the FWA base station peak throughput at busy hour by the customers' peak throughput at busy hour.

Figure 31 – Architecture of the FWA network

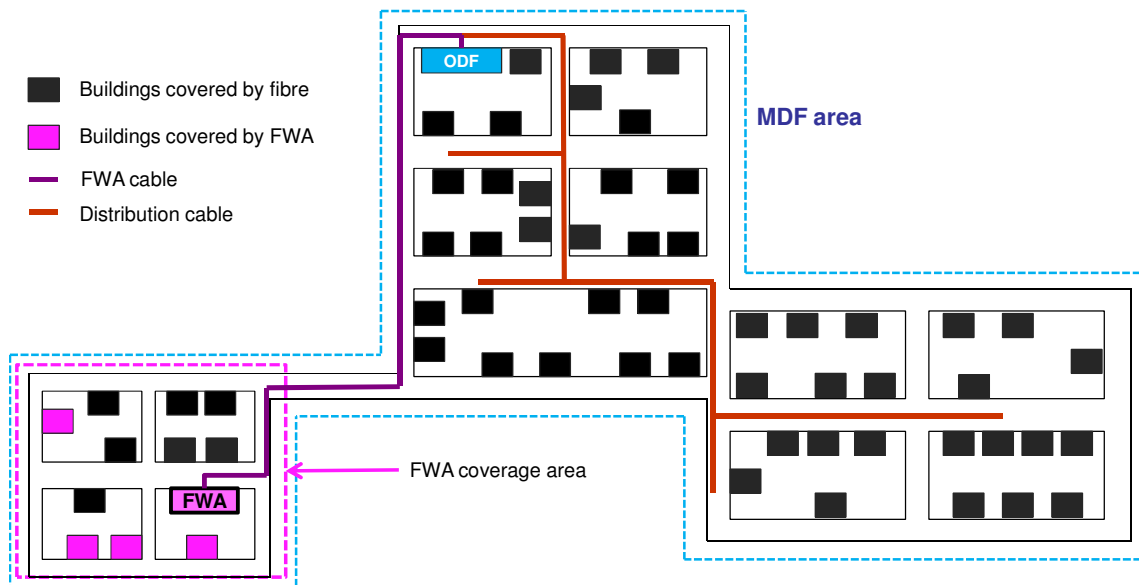

Source: TERA Consultants

The dimensioning of the FWA network is made jointly with the local access network dimensioning.

6.3 Network dimensioning

6.3.1 Base stations

There is one LTE advanced base station at each FWA site.

6.3.2 Cables

FWA sites are fed through 24F fibre cables from the nearest ODF, following the shortest path algorithm.

6.3.3 Joints

On sections crossed by a FWA cable, joints are used following the same rules as for the distribution fibre cables (see §5.3.3.2).

Joints are located whenever the cable length on the section exceeds the drum length of the cable.

There is at least one joint per cable on sections crossed by a FWA cable.

6.3.4 Civil engineering

FWA cables are buried and protected within sub-ducts. The dimensioning of the civil engineering assets allocated to the FWA network is detailed in §4.3.4 and §5.3.4.

6.4 Civil engineering sharing

Sharing with other infrastructures and asset re-use follow the same rules in the copper and fibre networks (see §4.4).

7 Equipping the core network

This section describes the core network cost modelling approach.

7.1 Structure of the network

Due to history, Chorus' network is made of several networks. An ATM network is partly used to provide some DSL services, and other data or voice services. However, in line with criterion 35 of the Model Reference Paper, the MEA for the UBA service is based on a NGN Ethernet network. Therefore the other networks are disregarded and are not modelled. The modelled NGN Ethernet network assigns the ATM DSL customers to the NGN Ethernet network.

The modelled core network used to provide DSL is made of 6,286 nodes (790 exchanges and 5,496 active cabinets) at which DSLAMs are installed. These sites do not reconcile entirely with the access network, however a best match has been used to reconcile the data. These DSLAMs are aggregated by FDS. These FDS are located on 92 sites, collocated with 92 of the 790 exchanges. These FDS are also referred as EAS in Chorus' Network. The modelled NGN Ethernet network is therefore based on these 6,286 sites.

Chorus' NGN Ethernet network consist of five independent REN (Regional Ethernet Network) covering the country linking the switches together. These REN carry the Ethernet traffic, except the traffic of the new fibre services (UFB).

Each REN is made of several open rings aggregating all switches sites.

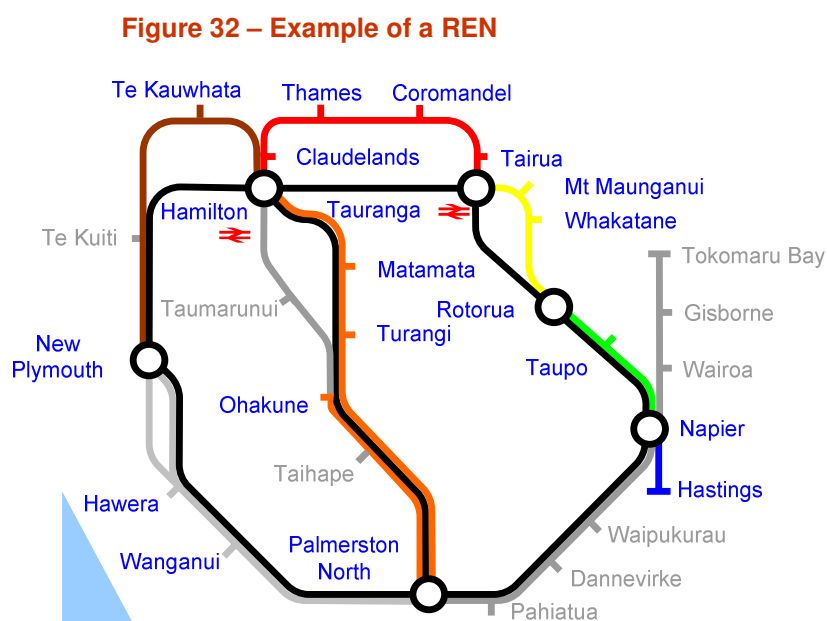

Source: Chorus

These rings are however not used for the UBA service, and are therefore not modelled in the core network. However the fibre rings are modelled as part of the passive network (modelled in the access network cost model) in order to take into account

economies of scope because the fibre cables of these rings use the same trenches as other parts of the network relevant for UCLL and UBA.

The UBA service stops at the FDS, and is therefore a local service. It can however be extended by subscribing to either a service called TES (Tail Extension Service) or regulated UBA backhaul service. This TES service is not modelled in the Core model as it is an unregulated service.

Figure 33 – Description of the UBA in the STD for Chorus UBA

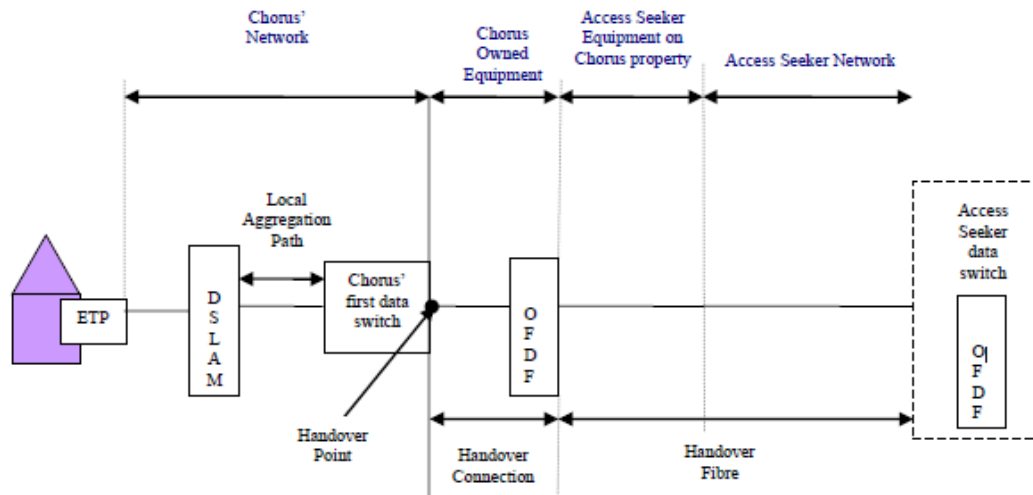

Source: STD FOR CHORUS' UNBUNDLED BITSTREAM ACCESS SERVICE SCHEDULE 1 UBA SERVICE DESCRIPTION

Figure 34 – Scope of the core modelling

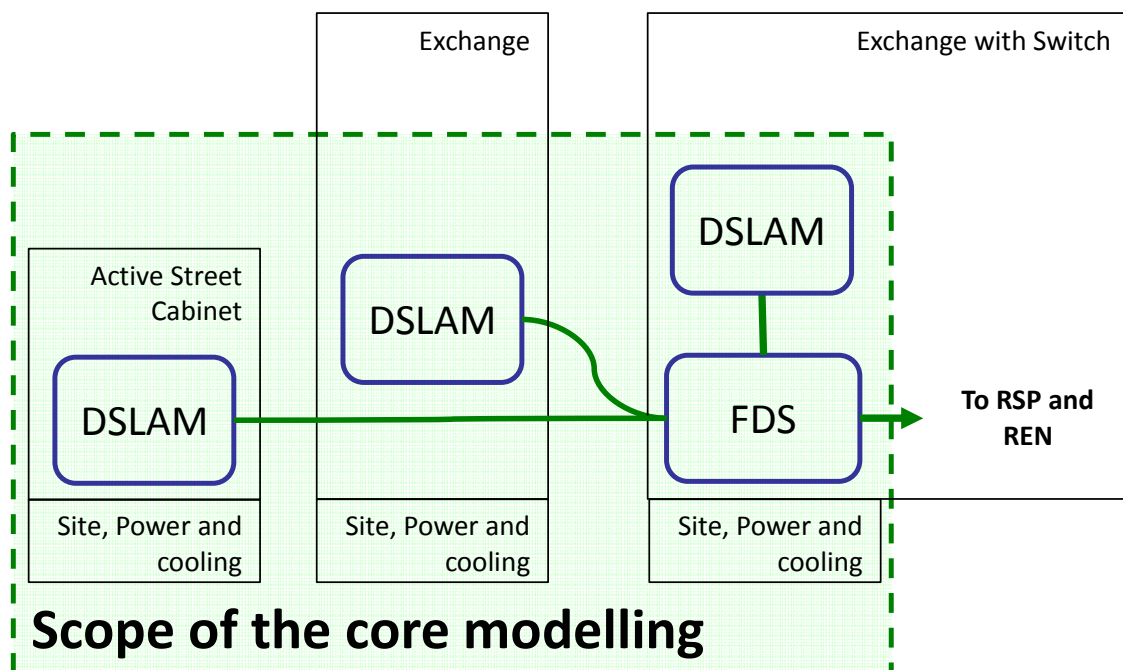

Source: TERA Consultants

7.2 Number of subscribers

The number of subscribers has been provided by Chorus for 2014 for all UBA services. In line with the Model Reference Paper, the demand consists of solely the actual UBA demand. At the DSLAM level, the number of subscribers modelled includes the three following categories of customers using regulated and commercial offers:

- UBA customers (BUBA and EUBA, about 1.1 million connections in 2013);
- VDSL customers (about 80,000 customers); and
- SHDSL customers (about 20,000 customers).

The copper network accounts for about 1.8 million connections in 2013. It offers several services, including all UBA, VDSL and SHDSL customers, plus some additional customer services or unbundled lines. These additional services account for approximately 600,000 lines.

It has to be noted that the figures provided come from different sources in Chorus, and may have been measured at different time. The total number of copper connections observed by Chorus may therefore slightly differ (about 3%) from the total provided in the model.

Customers such as PSTN customers and other services using legacy equipment or an independent network (e.g. fibres used to feed mobile stations) are not considered in the modelling. However as they may use the same fibre cables (but different fibres), cables used to provide the UBA service are considered to be shared with these services. Therefore only a share of the total costs of these cables is allocated to the UBA service (see §8.7.2.2).

7.3 Engineering rules of active assets

Several different network active pieces of equipment are modelled:

- DSLAM at Cabinet;
- DSLAM at Exchange; and
- First Data Switch.

Their engineering rules have been provided by Chorus. These reflect standard rules used by constructors that are publicly available. These engineering rules are described successively below.

7.3.1 DSLAMs

The DSLAMs are made of three different assets:

- The line card, where the customer copper line is terminated;
- The subrack holding the line cards and processing the traffic; and
- The rack holding the subracks.

The DSLAMs at the cabinet and at the exchange are made of the same types of assets. However their capacity is different.

7.3.1.1 DSLAMs at cabinet

The dimensioning rules are presented in the figure below:

Figure 35 – DSLAMs dimensioning

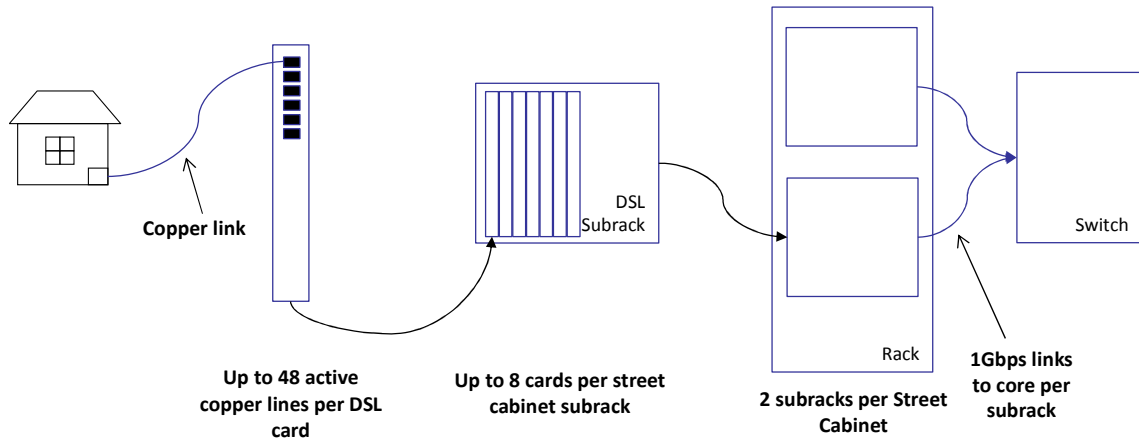

Source: TERA Consultants

The dimensioning rules for cards are the following:

- 48 copper lines per DSL card (1 port per active line); and
- 24 copper lines per SHDSL card (1 port per active line).

The dimensioning rules for subracks are the following:

- Up to 8 cards per street cabinet subrack.
- A subrack is linked to the FDS by a 1Gbps fibre link.

A rack can hold up to two subracks.

Given the dimensioning rules, a subrack can serve up to 384 (=48*8) DSL customers. The 1Gbps fibre link between the subrack and the FDS grants more than 2.6 Mbps of throughput at busy hour per customer. This is far more than what are currently experiencing the customers is and therefore sufficient to allow traffic growth.

7.3.1.2 DSLAMs at Exchange

The dimensioning rules are presented in the figure below:

Figure 36 – DSLAMs dimensioning

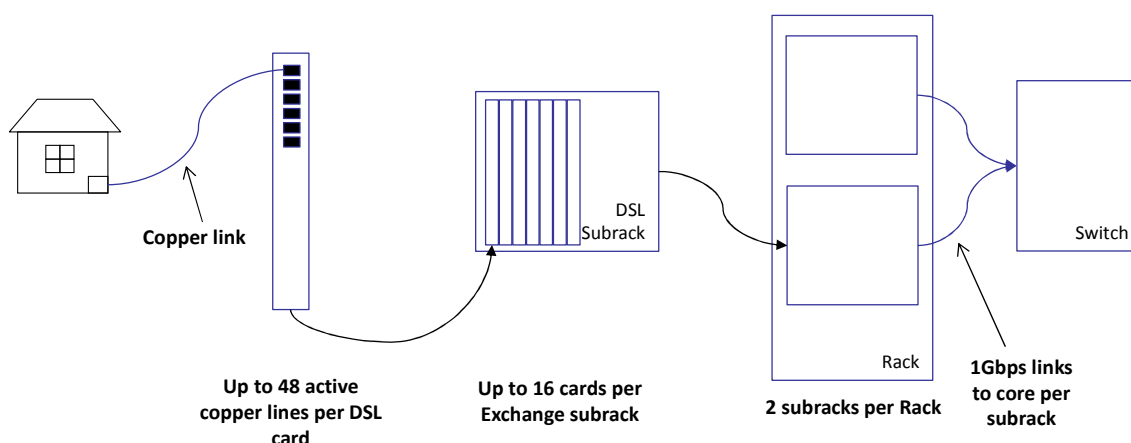

Source: TERA Consultants

The dimensioning rules for cards are the following:

- 48 copper lines per DSL card (1 port per active line); and
- 24 copper lines per SHDSL card (1 port per active line).

The dimensioning rules for subracks are the following:

- Up to 16 cards per exchange subrack.
- A subrack is linked to the FDS by a 1Gbps fibre link.

A rack can hold up to two subracks.

7.3.2 FDS

The FDS is made of four assets:

- The Small Form factor Pluggable (SFP);
- A line card;
- A subrack; and
- A rack.

The dimensioning rules of these 4 assets are presented in the figure below:

Figure 37 – FDS dimensioning

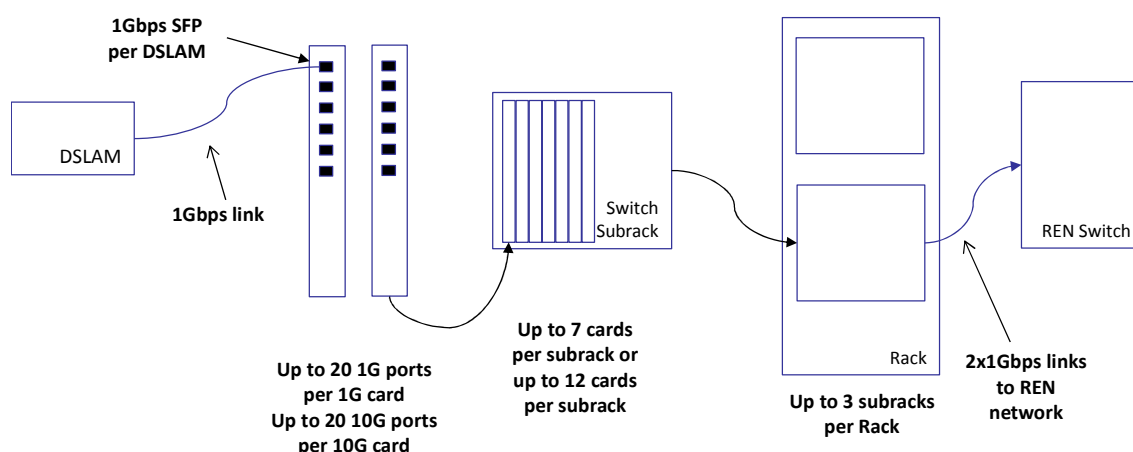

Source: TERA Consultants

One SFP is required per active port to connect the fibre (1 SFP per DSLAM subrack connected to the switch and 1 SFP per fibre link between the switch and another switch).

The dimensioning rules for cards are the following:

- 20x1Gbps ports per 1G-card; and
- 1x10Gbps ports per 10G-card.

The dimensioning rules for subracks are the following:

- Up to 7 cards per subrack 7; or
- Up to 12 cards per subrack 12.

A rack can hold up to three subracks.

The choice between the subrack 7 and the subrack 12 is based on the following rules:

- The number of subrack 12 is calculated by the formula: $\frac{\text{Floor}(\text{number of cards})}{12}$, where 12 is the capacity of the subrack 12; and
- The remaining cards are installed in either a subrack 7 if there are less than 7 remaining cards or in a subrack 12 if there are between 8 and 12 cards.

7.4 Civil engineering

7.4.1 Trenches, ducts and cables

7.4.1.1 Cables

The DSLAM-to-Exchange links use 12F underground fibre cables. The DSLAM-to-Exchange links follow the shortest path algorithm.

The other core network levels (Exchange-to-FDS and inter-EAS) use 24F underground fibre cables.

This size of cable is standard in other countries for this type of usage and therefore been based on international best practices in the absence of information provided by Chorus.

Figure 38 – DSLAM-FDS fibre cables

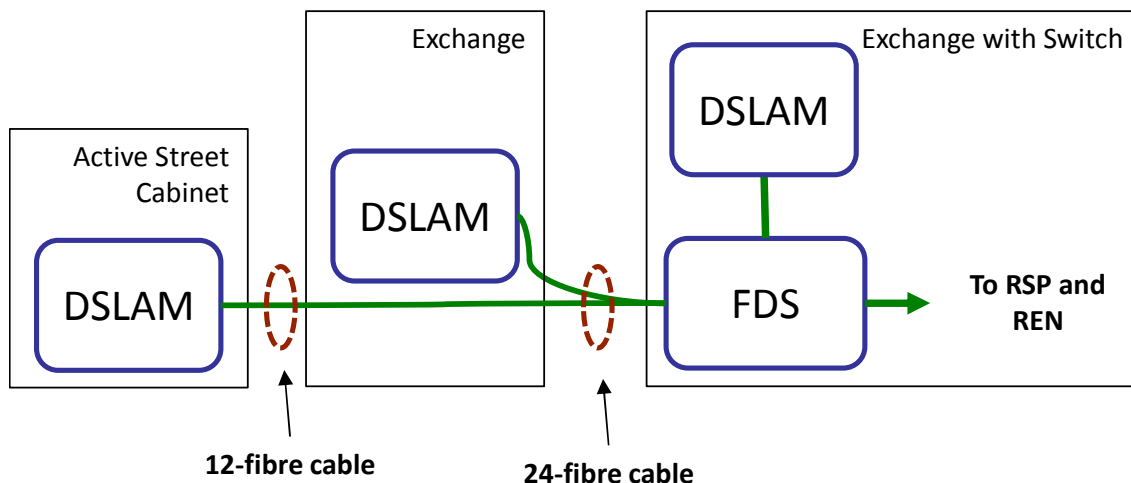

Source : TERA Consultants

7.4.1.2 Trenches, ducts and manholes

The dimensioning and allocation of trenches, ducts and manholes follow the same rules as in the copper and fibre access networks (§4.3.4 and 5.3.4).

As mentioned in §4.3.4.3.3, core cables are protected within sub-ducts.

7.4.2 Other links

As described in the Model Reference Paper, the core network can use other-than-pure fibre types of links:

- Submarine links;
- Microwave links;
- DWDM links.

The core network uses a submarine links to link islands. In such case, there is a submarine cable. Whenever stated by Chorus, a landing station is installed.

When the core network uses a microwave link, there is no equipment along the section. However at both ends of each link there is a microwave station.

When the core network uses a DWDM link on a section, there is a fibre along the section. At both ends of each DWDM link, a DWDM platform is installed.

8 Network and services costing

8.1 Unit costs input

8.1.1 Unit costs

The starting point to set the unit costs is to use the data provided by Chorus during the data collection.

The unit costs of some assets such as the active assets of the core network are quite uniform across the world as there is an international market for these assets.

The unit costs of the material of some passive assets such as the cost of ducts or the cost of cables are also quite uniform as these assets are standard (however the installation costs of these latter assets may vary a lot from one country to another). Such passive assets include, but are not limited to:

- Cables;
- Joints;
- Distribution points;
- Street cabinets;
- MDF/ODF; and
- FWA base stations, submarine landing stations.

The unit costs of these assets have therefore been benchmarked in order to assess whether the unit costs provided by Chorus are in line with what has been observed in other jurisdictions or not. When the unit costs seem unrealistic, the benchmarked unit costs have been used.

For assets for which Chorus did not provide unit costs, such as distribution points, street cabinets, MDF/ODF are inferred from benchmarks with other countries.

The unit cost of other assets such as trenches can vary a lot from one country to another as it depends on local parameters such as the local wages.

8.1.2 Copper cable unit costs

The material part of the unit costs of the copper cables is highly correlated to the price of copper on the international trade markets such as the London Metal Exchange. It is therefore expected that a larger copper cable will cost more than a smaller copper cable.

However there is another parameter that will impact the unit cost of copper cable which is the demand. Large orders will lead to discounts. It is therefore not inconsistent to have unit costs of some larger copper cables being lower than the unit costs of some smaller copper cables if they are not bought in same quantities.

8.1.3 Trenching unit costs

One of the main cost categories of a fixed network is the cost of trenching which is difficult to benchmark as it depends on:

- The wages;
- The type of soils and the trenching technology;
- The trenching rules.

Specific attention has therefore been given to the trenching costs.

The model uses the NZRI 66 soil classification which includes 5,147 different types of soil. For each of these types of soil, the cost efficient trenching technology has been identified among the following ones:

- Chain digger;
- Open trench 400 mm wide;
- Open trench 600 mm wide;
- Directional drilling;
- Rock saw 600 mm deep; and
- Thrust boring.

The scope of the trenching cost includes the following tasks:

- Excavation;
- Duct supply and installation;
- Backfill;
- Surface reinstatement;
- Consenting; and
- Traffic management.

For each of these tasks, the efficient unit cost has been assessed by independent consultants, Beca.

8.2 Spectrum costs for FWA

The spectrum costs should be included in the valuation of the FWA costs. Spectrum costs have been assessed at the reserve value of the latest auction for the 700 MHz band.

8.3 Price trends

Due to the separation between Spark (Telecom) and Chorus, setting price trends based on historical Chorus procurement data has not been possible.

As a consequence, several approaches have been envisaged to derive price trends for the different assets and opex categories:

1. **Cost escalation:** Identifying the relevant index or set of indices the asset category cost is supposed to evolve with. These are chosen among:

- The consumer price index (CPI)⁵: Applied to miscellaneous material parts.
 - The labour cost index (LCI)⁶: Applied to installation parts of assets and labour related opex.
 - The fabricated steel index⁷: Applied to the material part of ODF/MDF costs.
 - The copper index⁸: applied to the copper part of copper cable material cost.
 - The fibre optic cabling index⁹: applied to the material part of optical fibre cables.
2. **The ‘default’ approach**: When no better data is available, it is proposed to use international benchmark for active equipment, the CPI for passive equipment and the LCI for labour related opex.
 3. **International benchmark**: Average price trends assumptions within publicly available TSLRIC models (Australia, Denmark, Sweden, France, Norway).
 4. **Beca estimates**: The Beca experts have provided estimates for ducts and trenches price trends in the NZ context.

It should be noted that all indices inputs used in these calculations have been corrected for purchasing power parities differences.

Then, the “preferred approach” among the four available has been selected with the following rules:

- The Escalation approach (#1) is chosen for passive equipment (except ducts and trenches) if a relevant index or set of indexes can be found. If not, the CPI is used (#2).
- Beca estimates (#4) are used for ducts and trenches as these price trends are closely related to the NZ context.
- Active equipment price trends are derived from international benchmarks (#3) as the market for active equipment is international.
- Labour related opex evolves with the LCI (#1).
- Non-labour related opex evolution is very hard to forecast so those costs are assumed to remain stable.

The selected price trends assumptions are listed in the table below:

⁵ Source: Table A7 CPI, NZIER forecasts based on Statistics New Zealand

⁶ Source: Table A18 Private sector wages & total labour cost index, NZIER forecasts based on Statistics New Zealand

⁷ Source: NZIER

⁸ Source: NZIER

⁹ Source: Stats NZ

Figure 39 – Selected price trends for the different assets / opex categories

	Escalation	'default' approach	International benchmark	Beca	Preferred approach	Selected price trend
	1	2	3	4		
Copper cables	2.8%	2.2%			1	2.8%
Copper joints	2.5%	2.2%			1	2.5%
Copper Distribution points	2.4%	2.2%			1	2.4%
Fibre Distribution points	2.5%	2.2%			1	2.5%
Fibre cables	4.2%	2.2%			1	4.2%
Fibre joints	2.5%	2.2%			1	2.5%
Ducts	2.2%	2.2%		3.0%	4	3.0%
Trenches	2.5%	2.2%		3.0%	4	3.0%
Poles	2.4%	2.2%			1	2.4%
Chambers/Manholes/Jointholes	2.5%	2.2%			1	2.5%
MDF/ODF	1.6%	2.2%			1	1.6%
FWA base stations – Active	2.2%	-5.0%	-5.0%		3	-5.0%
FWA base stations – Passive	2.2%	2.2%			2	2.2%
Submarine links (cables/landing stations)	2.2%	2.2%			2	2.2%
Microwave links	2.2%	2.2%			2	2.2%
DWDM links (active part)	2.2%	-4.8%	-4.8%		3	-4.8%
DSLAM (card/subrack/rack)	2.2%	-4.8%	-4.8%		3	-4.8%
Switches/routers (card/subrack/rack/SFP)	2.2%	-5.0%	-5.0%		3	-5.0%
Building/Land	2.2%	2.2%			2	2.2%
Power equipment	2.2%	2.0%	2.0%		3	2.0%
Air-conditioning equipment	2.2%	0.5%	0.5%		3	0.5%
Site equipment (e.g. security equipment)	2.2%	2.2%			2	2.2%
Opex – labour related	2.6%	2.6%			1	2.6%
Opex – Non-labour related	0.0%	0.0%			1	0.0%
Spectrum	0.0%				1	0.0%

Source: TERA Consultants

8.4 Asset lives

TERA have used the following list of asset lives. [] CNZRI

8.4.1 Asset lives for the TERA Access Network

Table 4 – Assets life for the TERA Access Network

Asset category	Asset life	[]
Copper cables, joints and distribution points underground	20	[]
Copper cables, joints and distribution points overhead	14	[]
Fibre cables, joints and distribution points	20	[]
Underground infrastructure	50	[]
Overhead infrastructure	20	[]
Street cabinets	14	[]
MDF/ODF	20	[]
FWA base stations and MW sites	14	[]
Submarine links	20	[]
DWDM sites	10	[]
FWA spectrum	17	[] CNZRI

Source: TERA Consultants

8.4.2 Asset lives for the TERA Core Network

Table 5 – Assets life for the TERA core network

Asset category	Asset life	[]
DSLAM	7	[]
FDS	5	[]
Power	15	[]
Cooling	15	[]
Site	18	[] CNZRI

Source: TERA Consultants

8.5 Cost of capital

For the costs that are valued bottom-up, the cost of capital is embedded in the annuity calculated. The nominal pre-tax WACC is used to feed the depreciation factor (see §8.6).

For the costs that are assessed top-down based on Chorus' accounts, the cost of capital is assessed by multiplying the net book value by the nominal pre-tax WACC. The depreciation cost as provided by the accounts is not including the cost of capital. It therefore has to be included. The nominal pre-tax WACC is derived from the nominal post-tax WACC using the following formula:

$$WACC_{Pre-Tax} = \frac{WACC_{Post-Tax}}{(1 - \text{Legal Corporate Tax rate})} \text{ where the Legal corporate tax rate is 28\%}$$

8.6 Annuity calculations

The annuity calculation is based on the tilted annuity formula. In line with criterion 59 of the Model Reference Paper, a tax adjusted annuity is used.

8.6.1 Time to build

In line with criterion 60 of the Model Reference Paper, the time to build has been set to 6 months.

8.6.2 Tax depreciation rates

The first step of this approach is to define for each asset class a tax depreciation rate that reflects the tax shield.

Table 6 – Tax depreciation rate

Asset class	Tax depreciation rate
Copper cables	13%
Copper joints	13%
Copper Distribution points	13%
Fibre Distribution points	13%
Fibre cables	13%
Fibre joints	13%
Ducts	4%
Trenches	4%
Poles	10%
Chambers/Manholes/Joint-holes/Pits	4%
MDF/ODF	16%
Switches/routers	20%
FWA base stations	8%
FWA spectrum	20%
Submarine links (cables/landing stations)	8%
Microwave links	12%
DWDM links	13%
DSLAM (card/subrack/rack)	16%
Switches/routers (card/subrack/rack/SFP)	16%
Building/Land	3%
Power equipment	8%
Air-conditioning equipment	16%
Site equipment (e.g. security equipment)	20%

Source: The Commission based on IRD's general depreciation rates

These values are in line with the values described in the Commission's Attachment I of the draft determination for UBA and Attachment K for UCLL.

8.6.3 Adjustment to pre-tax annuity

The prices that are derived in the model are pre-tax prices. It is therefore required to adjust the post-tax annuity in order to take into account the level of tax paid. This adjustment is based on the tax depreciation rate defined in the previous section using the following formula:

$$\text{Adjustment to Pre Tax annuity} = \frac{1 - \frac{\text{Corporate Tax Rate} * \text{Tax Depreciation Rate}}{\text{Tax Depreciation Rate} + \text{WACC}_{\text{Post-Tax nominal}}}}{1 - \text{Corporate Tax Rate}}$$

8.6.4 Post-tax real WACC

The third step is to derive a post-tax real WACC based on the post-tax nominal WACC. This is achieved by using the following formula:

$$\text{Post Tax real WACC} = \frac{1 + \text{WACC}_{\text{Post-Tax nominal}}}{1 + \text{Price Trend}} - 1$$

8.6.5 Annuity

The final step is to determine the annuity. It is obtained by computing the annuity of the total investment using:

- The interest rate as defined by the post-tax real WACC;
- The asset life; and
- The annuity is corrected by the adjustment to pre-tax annuity.

The Excel formula used is therefore the following one:

$$\text{Annuity} = \frac{\text{Investment} * \text{Adjustment to Pre Tax Annuity}}{\text{Price Trend}}$$

8.7 Cost allocation

In line with criterion 54 in the Model Reference Paper, the capacity-based allocation approach is used for the infrastructure and equipment costs allocation in UCLL and UBA.

8.7.1 Capacity-based allocation for UCLL

The different infrastructure assets involved in the local access network may be shared with other network levels (FWA, core network, and SLU backhaul). The cost of each asset has to be allocated between the different network levels.

For each asset, the allocation key is computed at the dimensioning step, following the capacity-based approach, consistent with the dimensioning driver.

- The costs of trenches and manholes are allocated on the basis of the ducts in the trench (see §4.3.4.4.2).
- The costs of ducts are allocated on the basis of the cables surfaces, when copper, and on the basis of the sub-ducts surface, when fibre (see §4.3.4.3.)

- The costs of poles are allocated on the basis of the equipment carried by the poles, i.e. the number of joints (see §4.3.4.2.). E.g. if a pole is carrying three joints, 2 used by feeder and one by the distribution, then 2/3 of the cost of the pole is allocated to the feeder and 1/3 to the distribution.

8.7.2 Capacity-based allocation for UBA

8.7.2.1 Active assets

The different active assets involved in the UBA service provision may be shared with other services, such as Chorus' SHDSL-based high speed network service. The cost of each asset therefore has to be allocated between the different services.

The allocation key should be consistent with the dimensioning driver (capacity-based allocation approach). Thus, for each asset, a dedicated allocation key has to be computed. As all active assets of the core network are dimensioned based on the number of customers, the allocation keys will be the relevant number of customers. E.g. for a DSLAM located in a cabinet, the costs of the rack and the subracks will be allocated based on customers connected to the cabinet, a xDSL card will be fully allocated to the xDSL service and a SHDSL card will be fully allocated to the SHDSL service.

The FDS are also used for the REN interconnection for RSP who are interested in buying a TES. This means that a small part of the FDS costs have to be allocated to interconnection links. Therefore FDS costs are allocated partly to interconnection links, based on the number of ports used:

- To connect the FDS to the REN (allocated to other services);
- To connect the RSP (allocated to other services); and
- To connect the DSLAMs (allocated to UBA).

It should be noted that, in other jurisdictions, the key generally used to allocate the cost of the active assets is the traffic. However, the definition of the core UBA network in other jurisdictions is much broader as it includes not only the exchange to FDS link but also inter-FDS link, national backbone, etc. And because in these other parts of the core network, traffic is the driver, traffic is often used as a driver for the whole core network. However in New Zealand, the scope of the core network used to provide UBA is limited to the part between the exchange and the FDS. And this part of the core network is not dimensioned based on the traffic as the true dimensioning factor is the number of customers. Therefore the allocation key that has to be used in New Zealand is different from what is generally used in other jurisdictions.

8.7.2.2 Passive assets

The access network cost model provides the cost of the fibre links between the cabinets and the exchanges, and between the exchanges and the FDS. These links are not dedicated to the provision of UBA, but are shared with other services such as leased lines, legacy services or dark fibre services. The cost of these links has therefore to be allocated to each service.

Given that no data have been submitted by Chorus about fibre usage during the data collection phase, two assumptions have been made:

Table 7 – Cost allocation of the links

Parameter	Share allocated to bitstream services	Share allocated to other services
Link between active cabinets and their parent exchange	2/3	1/3
Link between exchanges and their parent FDS exchange	1/3	2/3

Source: TERA Consultants

The assumption used for the cost allocation of the link between active cabinets and their parent exchange is based on the fact that in average two fibres would be used by bitstream (one for each subrack) and one fibre would be used by the access part of a leased line (see §3.8). This is an average value since in some cases there may be no fibre used by the access part of a leased line and in some cases there may be several fibres used by the access part of a leased line.

The assumption used for the cost allocation of the link between exchanges and their parent FDS exchange is based on the fact that there are three services (bitstream, voice and leased lines) using this link and the cost should therefore be split between these 3 services

The costs allocated to bitstream services (regulated and unregulated) are then split based on the number of customers¹⁰.

8.8 Indirect capex costs

Some costs are modelled neither in the access network cost model nor in the core network cost model and have to be taken into account.

There are named “Indirect Capex” and have to be allocated to the different services in the core network cost model.

In line with the criterion 55 in the Model Reference Paper and the methodology traditionally used by NRAs, the EPMU approach has been implemented.

Two types of indirect capex are included:

- IT costs indirect capex; and
- Miscellaneous indirect capex.

The IT costs include hardware and software costs related to network, billing platforms, network management platforms, Information system platforms, etc.

¹⁰ These parameters are available in the model ‘Parameters’ spreadsheet, section ‘Share of civil engineering allocated to UBA’.

The Miscellaneous indirect capex include costs related to office equipment, furniture, tools and plants, and motor vehicles.

These costs are derived in the Opex model.

8.9 Services costing

8.9.1 Costing of the UBA

UBA is a service based on the copper local loop. The UCLL should therefore be computed with the copper roll-out scenario. The UBA cost is obtained with the following formula:

$$UBA = UCLL_{Copper\ based} + UBA\ additional\ costs$$

Where the UBA additional costs includes:

- The cost of the SLUBH;
- The cost of the link between the different exchanges and their parent exchanges where their FDS is located;
- The cost of the DSLAM; and
- The cost of the FDS.

8.9.2 Costing of the UCLL and the SLU

8.9.2.1 Lowest cost roll-out scenario

The costing of the UCLL is based on the cheapest roll-out scenario among the fibre access network costing (including FWA) and on the copper access network costing:

The choice of the cheapest configuration can be either performed at:

- The MDF level;
- National level.

In line with the criterion 10 of the Model Reference Paper, the choice of the cheapest configuration is performed at the national level.

8.9.2.2 Double recovery between UCLL and UBA

The scope of the copper network is different from the scope of the fibre network. The fibre network is using the same exchange nodes and the same exchange coverage areas as the copper network. However the copper network uses active street cabinets. The demarcation point between the access network and the core network is therefore not the same between the copper network and the fibre network.

Figure 40 – Demarcation point of the copper and of the fibre networks

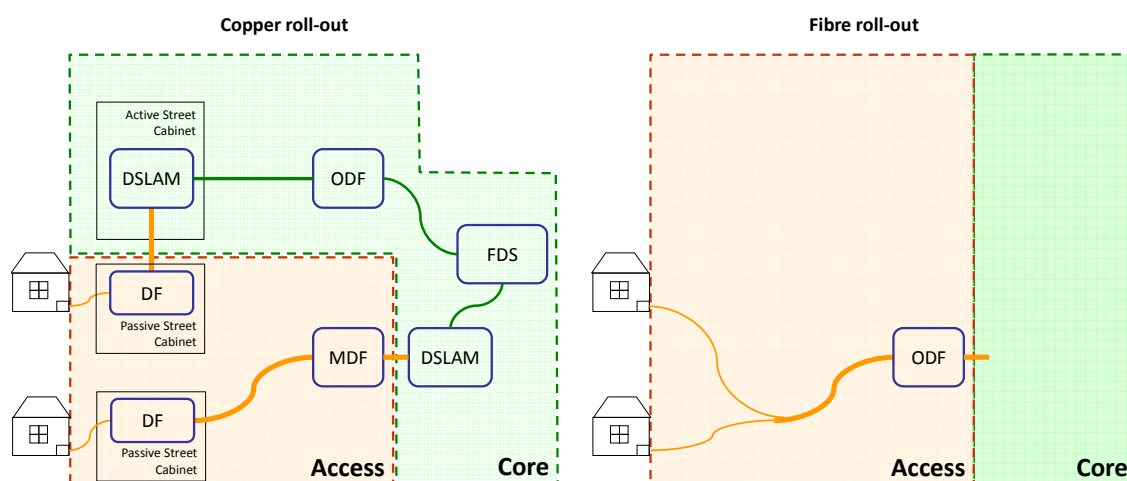

Source: TERA Consultants

The core network starts at the active street cabinets for the lines that are aggregated on active street cabinets and at the exchange for the lines aggregated at the exchange whereas the core network always starts at the exchange for the fibre network. It is therefore important to ensure that no cost is recovered twice and that all costs are recovered.

8.9.2.2.1 Copper is the lowest cost configuration

If copper is the cheapest configuration in a MDF, then there is no double recovery between UBA and UCLL as the UBA is always based on a copper local loop.

8.9.2.2.2 Fibre is the lowest cost configuration

As the fibre network modelled uses the exact same exchanges as the copper network modelled, there is no double recovery possible for the part between the exchange and the FDS.

The fibre network aggregates all customers at the exchange whereas to aggregate all customers at the exchange for the copper network, a combination of the local loop plus the SLUBH is needed.

If fibre is the lowest cost configuration in a MDF, then there is an overlap between the costs recovered by the UBA and the costs recovered by the UCLL:

- The SLUBH is recovered by the UBA; and
- The fibre loop allows recovering the cost of aggregating all customers at the exchange, i.e. the SLUBH is included in the scope of the fibre loop.

If fibre is the cheapest configuration, then an adjustment is required to prevent the SLUBH being recovered twice. The cost of the SLUBH should therefore be excluded from the cost of the fibre loop.

8.9.2.3 Selecting the cheapest configuration

UCLL is the cost of the access network either based on a copper loop or on a combination between a fibre loop and the FWA technology. In line with the criterion 10,

the cheapest configuration should be selected. In order to compare networks with the same scope and therefore to have comparable configurations the cost of the copper local loop is compared with the cost of the fibre local loop (+FWA) minus the cost of the SLUBH.

If the cost of the copper configuration is the cheapest, then the UCLL is based on the copper configuration.

If the cost of the fibre configuration minus the cost of the SLUBH is the cheapest, then the UCLL is based on the fibre (+FWA) configuration minus the cost of the SLUBH.

8.9.2.4 Costing the UCLL and the SLU

Having selected the cheapest configuration, the sum over all MDF provides the total cost of the loop (the cost of ULL), i.e. the total cost of the sub-loop for the lines aggregated at an active cabinet plus the total cost of the loop for the lines aggregated directly at an exchange (going through or not a passive cabinet).

The cost of the SLUBH is an output of the model as it is a direct result of the capacity-based allocation.

The following notation is used:

#ULL = Number of active lines

#SLU = Number of active lines connected to an active cabinet

#SLUBH = Number of active customers using the SLUBH

It is assumed that #SLU= #SLUBH, i.e. that there is no unbundling at the cabinet.

C_{ULL} = cost of the ULL

C_{SLUBH} = cost of the SLUBH

P_{UCLL} = unit price of the UCLL

P_{SLUBH} = unit price of the SLUBH

P_{SLU} = unit price of the SLU

The cost of connecting all customers to an exchange is given by $C_{ULL} + C_{SLUBH}$

The average cost per line is therefore $\frac{C_{ULL} + C_{SLUBH}}{\#ULL}$

The cost per line should be the same whether the line is cabinetised or not:

$$P_{UCLL} = P_{SLUBH} + P_{SLU} = \frac{C_{ULL} + C_{SLUBH}}{\#ULL}$$

Therefore the unit price of the three access services are given by the following formulas:

$$P_{UCLL} = \frac{C_{ULL} + C_{SLUBH}}{\#ULL}$$

$$P_{SLUBH} = \frac{C_{SLUBH}}{\#SLUBH}$$

$$P_{SLU} = \frac{C_{ULL} + C_{SLUBH}}{\#ULL} - \frac{C_{SLUBH}}{\#SLUBH}$$

9 Verifications

9.1 Cost recovery

The formula used to calculate the unit price of the SLU, the SLUBH and the UCLL derived in §8.9.2.4 allows recovering the cost of the network.

The revenues generated are the unit price of each service multiplied by their demand:

$$\text{Revenues} = \#UCLL * P_{UCLL} + \#SLUBH * P_{SLUBH} + \#SLU * P_{SLU}$$

The unit price of the different access services are the following ones:

$$P_{UCLL} = \frac{C_{ULL} + C_{SLUBH}}{\#ULL}$$

$$P_{SLUBH} = \frac{C_{SLUBH}}{\#SLUBH}$$

$$P_{SLU} = \frac{C_{ULL} + C_{SLUBH}}{\#ULL} - \frac{C_{SLUBH}}{\#SLUBH}$$

The unit prices in the revenues formula can be replaced:

$$\text{Revenues} = \#UCLL * \frac{C_{ULL} + C_{SLUBH}}{\#ULL} + \#SLUBH * \frac{C_{SLUBH}}{\#SLUBH} + \#SLU * \left(\frac{C_{ULL} + C_{SLUBH}}{\#ULL} - \frac{C_{SLUBH}}{\#SLUBH} \right)$$

Given that:

$$\#SLU = \#SLUBH$$

$$\#ULL = \#UCLL + \#ULL$$

The revenues formula can be simplified:

$$\text{Revenues} = C_{ULL} + C_{SLUBH} = \text{Cost of the network}$$

The cost of the network is therefore recovered with the unit prices defined with the formulas set in §8.9.2.4.

9.2 Cross-checks

9.2.1 Access network dimensioning

The results of the Microsoft Access component of the access network cost model are checked on representative sections using an Excel replica of the access network dimensioning model. This allows easing the cross-checks and offers more transparency to the industry.

Thirteen representative sections – and their buildings – have been chosen to perform the cross-check analysis onto the Dimensioning at the section level and Dimensioning at the building level algorithms:

1. A section with no network;

TSLRIC price review determination for the Unbundled Copper Local Loop and Unbundled Bitstream Access services
Model Specification – Public Version

2. A section with only FWA or core network, underground;
3. A section with only FWA or core network, overhead;
4. A section with distribution only, underground, with one trench;
5. A section with distribution only, underground, with two trenches;
6. A section with distribution only, overhead;
7. A section with distribution and feeder, underground;
8. A section with distribution and feeder, overhead;
9. A section with distribution and core, underground;
10. A section with distribution and core, overhead;
11. A section with distribution, feeder and core, underground, with one trench;
12. A section with distribution, feeder and core, underground, with two trenches;
and
13. A section with distribution, feeder and core, overhead.

These 13 case studies represent all the possible situations.

All the input parameters of the Microsoft Access component of the access network cost model are compiled in the Excel cross-check file.

Figure 41 - Screenshot of the Access network cross-check: input parameters

Copper cables' inventory	Pairs	Diameter	Length	Description
ID Copper cable				
LeadinUG0002	2	5.6	2500	2 pairs UG copper cable
LeadinOH0004	4	8.9	300	4 pairs lead in aerial copper cable
LeadinOH0002	2	8.2	300	2 pairs lead in aerial copper cable
AccessUG2000	2000	67	500	2000 pairs UG copper cable
AccessUG0800	800	43.8	500	800 pairs UG copper cable
AccessUG0400	400	37.35	200	400 pairs UG copper cable
AccessUG0300	300	27.1	500	300 pairs UG copper cable
AccessUG0200	200	27.15	500	200 pairs UG copper cable
AccessUG0100	100	21.25	1000	100 pairs UG copper cable
AccessUG0050	50	15.55	1000	50 pairs UG copper cable
AccessUG0025	25	13.5	2000	25 pairs UG copper cable
AccessUG0015	15	9	1000	15 pairs UG copper cable
AccessUG0007	7	7.5	2000	7 pairs UG copper cable
AccessUG0005	5	6.7	500	5 pairs UG copper cable
AccessUG0004	4	6.4	1000	4 pairs UG copper cable
AccessOH0050	50	24.53333333	500	50 pairs aerial copper cable
AccessOH0025	25	24.6	500	25 pairs aerial copper cable
AccessOH0015	15	20.8	500	15 pairs aerial copper cable
AccessOH0010	10	20.2	500	10 pairs aerial copper cable
AccessOH0004	4	15.4	500	4 pairs aerial copper cable

Source: TERA Consultants

For each section, the section and its buildings inputs are retrieved from the Microsoft Access component of the access network cost model, i.e. the section-specific and building-specific data, as well as the local demand.

Figure 42 - Screenshot of the Access network cross-check: inputs

1 Section inputs									
At the building level	ID Section	Horizontal Length	Vertical Length	Nb Total	Right Side	Roadwidth	Urban	Nb_B	
ID Building									
697259	185538	7 075794	11 553237	1	FAUX	11.25	VRAI		
697296	185538	0	1.205043	1	VRAI	11.25	VRAI		
1449781	185538	13 554942	16 067277	1	VRAI	11.25	VRAI		
1586338	185538	19 636044	30 193896	1	VRAI	11.25	VRAI		
1659195	185538	28 211519	57 934411	1	VRAI	11.25	VRAI		
1659196	185538	10 077075	29 705070	1	FAUX	11.25	VRAI		
1672112	185538	25 189843	15 01779	3	FAUX	11.25	VRAI		
1706342	185538	28 211519	1 823652	3	VRAI	11.25	VRAI		
At the section level	Length	Roadwidth	Nb Dwelling	Nb Building	Urban	Nb_Sdu_Minor	Nb_Dwelling_Minor	Nb_Sc	
ID Section									
185538	28 211519	11.25	12	8	VRAI	2	5		

Source: TERA Consultants

TSLRIC price review determination for the Unbundled Copper Local Loop and Unbundled Bitstream Access services
 Model Specification – Public Version

Then, for each section and each building of the section, the outputs of the “Dimensioning at the section level” and of “Dimensioning at the building level” are computed within the Microsoft Excel file, using, if necessary interim, computations. The dimensioning is made following the exact same rules as described in this document and in the model documentation.

Figure 43 - Screenshot of the Access network cross-check: computations

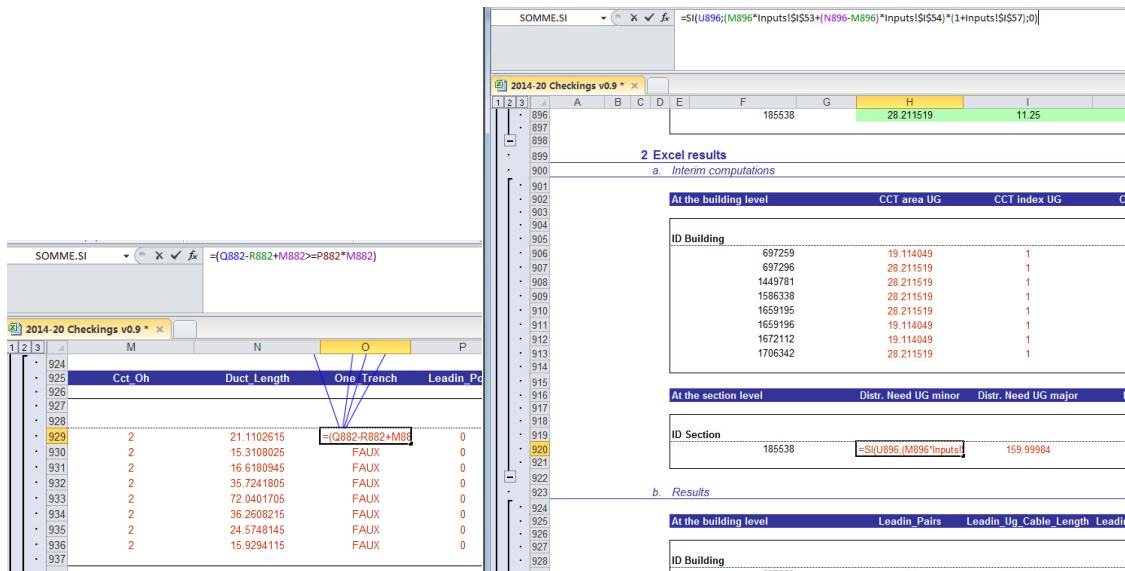

Source: TERA Consultants

Ultimately, the results of the Microsoft Access component of the network access cost model are retrieved into the Excel file and compared to the results of the Excel computations.

Figure 44 - Screenshot of the Access network cross-check: comparison between Access and Excel

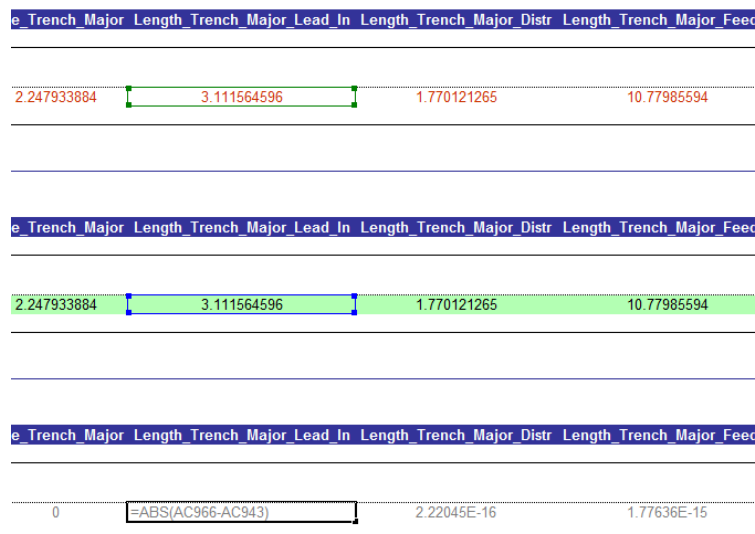

Source: TERA Consultants

If the difference between the Microsoft Excel and the Microsoft Access computation is lower than a given margin of error ($\epsilon = 10^{-12}$), then the test is conclusive.

Otherwise, the Microsoft Access component of the access network cost model is adjusted to meet the desired result.

9.2.2 Core model

In order to validate the core model, the inventory derived by the modelling is compared to Chorus' actual inventory.

Table 8 – Comparison of the inventories

Asset	Modelled inventory	Chorus' inventory
DSLAM subrack located in cabinets	[]	[]
DSLAM subrack located in exchanges	[]	[]
FDS subrack 7	[]	[]
FDS subrack 12	[]	[] CNZRI

Source: TERA Consultants

As the scope of the core model has been calibrated to model the UBA service, it is expected that the number of assets modelled is lower than the number of assets contained in Chorus' inventory.

10 Prices

10.1 Price control period

The price control period is the 2015-2019 period.

10.2 Prices over the price control period

For each service, a unique price is set over the price control period.

As the unit cost of the network assets are changing each year as all price trends are not null (see §8.3), the yearly prices will change every year. In order to set a stable price over the price control period, the yearly prices should be smoothed.

Given that the demand is assumed to be stable, the following smoothing formula will ensure both stable prices over the price control period and cost recovery:

$$Price = \frac{\sum_{i=1}^5 \frac{Price_i}{(1 + WACC_{posttax})^i}}{\sum_{i=1}^5 \frac{1}{(1 + WACC_{posttax})^i}}$$

10.3 Gradients

Given the different products that are modelled, the dimensioning of the core network is independent of the traffic (this is consistent with the engineering rules described in §7.3). The cost of providing the different UBA services is therefore the same. However, the unit price of the different UBA services should be different and reflect the different added value of each service.

In order to ensure cost recovery and price differentiation, a gradient approach has been used. The mark-up of the different UBA services is based on a benchmark:

Table 9 – Gradient mark-ups

Service	Mark-up
BUBA	0%
EUBA 40	21.32%
EUBA 90	26.57%
EUBA 180	36.02%

Source: TERA Consultants

10.4 Results

The TSLRIC model for UBA and UCLL have been constructed by following the principles and specifications described in the Model Reference Paper and in the present document. The results of the TSLRIC model are given in the table below, in NZD/month/line:

Table 10 – Results of the TSLRIC model for UCLL and BUBA

Chorus product	Price per customer and per month for the period 2015-2019 (NZD)
UCLL	28.22
BUBA	38.40

Source: TERA Consultants

10.5 Sensitivity analysis

In this section, the results of sensitivity analyses are provided.

For each sensitivity analysis, the prices of the following services are provided:

- UBA additional costs;
- SLU;
- UCLL.

In addition, the total annuities (depreciated capex for 2015) of the following network scopes are provided:

- UBA additional costs;
- SLU backhaul;
- Copper network;
- Fibre network.

The annuity of the fibre network has been adjusted to take into account the geographical scope difference with copper, i.e. the figure shown is the fibre network annuity minus the SLUBH annuity.

10.5.1 Sensitivity to the geographic scope: TSO-derived boundary

In the base case scenario, only the areas inside the TSO-derived boundary are taken into account to calculate the results. FWA coverage is based on the areas inside the TSO-derived boundary.

The scope of the cost modelling can be extended to the areas outside the TSO-derived boundary. In such scenario, the FWA coverage areas are based on the actual coverage, including the areas outside the TSO-derived boundary.

This scope extension leads to an increase in UCLL and SLU prices as the areas outside the TSO-derived boundary are the most remote areas of the network. It has of course a small impact on UBA.

Table 11 – Sensitivity to the TSO-derived boundary¹¹

Scenario	Annuity (mNZD)				Price (NZD/month/line)		
	UBA	SLUBH	Copper network	Fibre network	UBA	SLU	UCLL
Base case scenario	61.72	114.91	343.54	321.87	10.18	14.45	28.22
Including areas outside the TSO-derived boundary	62.19	114.93	493.55	460.94	10.14	22.53	35.21

Source: TERA Consultants

10.5.2 Sensitivity to the share of overhead network

In the base case scenario, the share of overhead network at the distribution and feeder levels is estimated at 36%.

A sensitivity analysis is run onto the model to assess the impact of the share of overhead network.

UCLL and SLU prices decrease when the share of overhead network is increasing.

The UBA price is slightly increasing because of the reallocation of common costs.

Table 12 – Sensitivity to the share of overhead network

Scenario	Annuity (mNZD)				Price (NZD/month/line)		
	UBA	SLUBH	Copper network	Fibre network	UBA	SLU	UCLL
Share of overhead: 20%	61.72	114.91	361.51	337.21	10.17	15.39	29.00
Base case scenario: 36%	61.72	114.91	343.54	321.87	10.18	14.45	28.22
Share of overhead: 62%	61.72	114.91	314.34	296.94	10.20	12.89	26.97

Source: TERA Consultants

¹¹ The TSO-derived boundary is based on the area defined in the TSLRIC model used for TSO. Each segment within the road network model was tagged with a TSO value of 'True' if 50% or more of its spatial definition fell within one or more of the convex polygons we calculated based on (December 2001) data about the extent of Telecom's network, otherwise the segment's TSO value was set at false. The convex polygons were derived from the historic customer locations for each exchange area which were grouped into clusters.

10.5.3 Sensitivity to price trends

As explained in §8.3, there are several sources for the price trends:

- The base case scenario corresponds to the most reasonable values identified among all sources.
- The low price trend scenario corresponds to the minimum price trends.
- The high price trend scenario corresponds to the maximum price trends.

As the price trends increase, the prices of the services decrease.

Table 13 – Sensitivity to price trends

Scenario	Annuity (mNZD)				Price (NZD/month/line)		
	UBA	SLUBH	Copper network	Fibre network	UBA	SLU	UCLL
Low price trend	69.68	148.67	442.11	402.34	10.65	16.69	32.80
Base case scenario	61.72	114.91	343.54	321.87	10.18	14.45	28.22
High price trend	56.84	114.91	343.30	321.65	10.08	14.44	28.21

Source: TERA Consultants

10.5.4 Sensitivity to asset lives

In the base case scenario, asset lives are based on Chorus data. However, some Chorus asset lives appear to be very low compared to all other sources. Thus, benchmark asset lives are used for such assets (see §8.4).

As a consequence, using Chorus asset lives leads to higher prices, in particular for the UBA.

Table 14 – Sensitivity to asset lives

Scenario	Annuity (mNZD)				Price (NZD/month/line)		
	UBA	SLUBH	Copper network	Fibre network	UBA	SLU	UCLL
Base case scenario	61.72	114.91	343.54	321.87	10.18	14.45	28.22
Asset lives based on Chorus accounting data	103.03	114.91	345.04	325.59	12.82	14.65	28.41

Source: TERA Consultants

10.5.5 Sensitivity to the capital contribution for RBI DSLAM

In the base case scenario, the investment of RBI DSLAM is removed.

Including the investment for RBI DSLAM increases the UBA price.

This leads to a reallocation of common costs and therefore leads to a decrease in the price of access products (SLU, UCLL).

Table 15 – Sensitivity to RBI DSLAM capital contribution

Scenario	Annuity (mNZD)				Price (NZD/month/line)		
	UBA	SLUBH	Copper network	Fibre network	UBA	SLU	UCLL
Base case scenario	61.72	114.91	343.54	321.87	10.18	14.45	28.22
Excluding capital contribution for RBI DSLAM	65.61	114.91	343.54	321.87	10.45	14.45	28.22

Source: TERA Consultants

10.5.6 Sensitivity to the cost adjustment method to select the cheapest technology

The costing of the UCLL is based on the cheapest roll-out scenario between the FTTH/FWA MEA and the FTTN MEA.

The choice of the cheapest configuration can be either performed at:

- The MDF level;
- National level.

In the base case scenario, the choice is performed at the national level.

The cost adjustment at the MDF level allows performing a greater adjustment on costs and therefore decreases the price of the access products (UCLL, SLU).

This leads to a reallocation of common costs and therefore leads to decrease the UBA price.

As the FTTH/FWA MEA network is cheaper than the FTTN MEA network, choosing a 100% FTTN network would lead to significantly higher prices for the UCLL.

Table 16 – Sensitivity to the cost adjustment method to select the lowest cost technology

Scenario	Annuity (mNZD)				Price (NZD/month/line)		
	UBA	SLUBH	Copper network	Fibre network	UBA	SLU	UCLL
Base case: cost adjustment at the national level	61.72	114.91	343.54	321.87	10.18	14.45	28.22
Cost adjustment MDF by MDF	61.24	114.91	343.54	321.87	10.09	13.09	26.86
100% copper	59.71	114.91	343.54	321.87	9.98	16.41	30.19

Source: TERA Consultants

10.5.7 Sensitivity to the Exchange-to-FDS link allocation

In the base case scenario, 33% of the Exchange-to-FDS fibre links are allocated to the UBA.

When the allocation key increases, the price of the UBA increases accordingly, mostly stemming from the Exchange-FDS fibre increasing cost.

Other costs are little-if-no affected.

Figure 45 – Sensitivity of the UBA additional cost to the share of the exchange to FDS link allocated to UBA

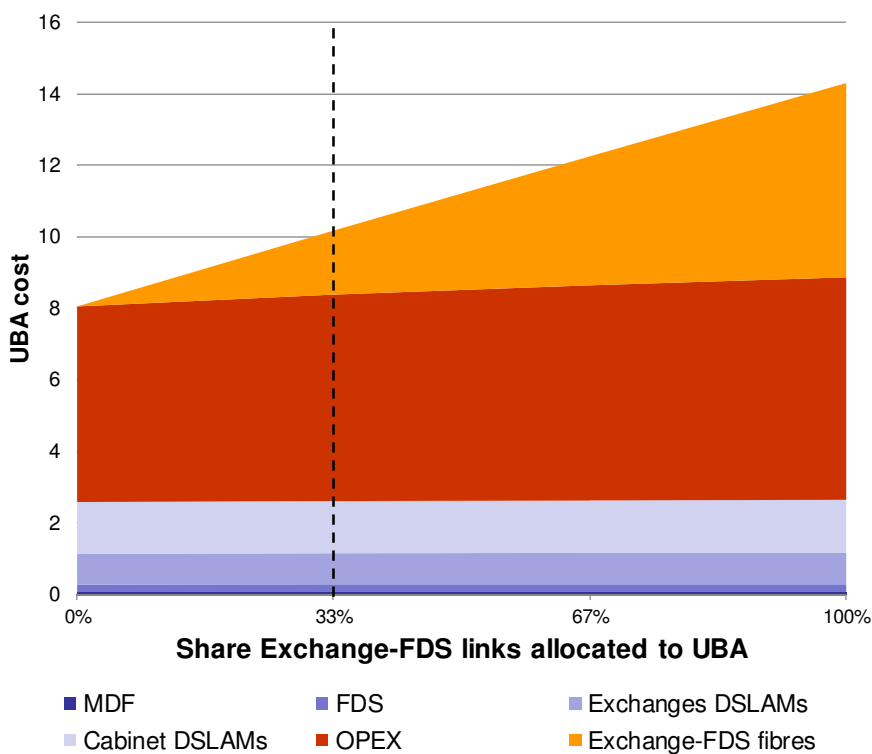

Source: TERA Consultants