



CSA Service Appendix - Schedule 2

Draft Service Description for the Commercial
Handover Connection Service

August 2014

1. Interpretation

- 1.1. References to clauses or sections are references to clauses or sections in this Service Description unless expressly provided otherwise.
- 1.2. References to Chorus' website are to the secure web portal that Chorus makes available to the Service Provider.
- 1.3. The definitions set out in the General Terms, the Special Terms and the Operations Manual apply to the extent that they are not expressly modified by or inconsistent with the context of this Service Description.
- 1.4. References to the Special Terms, Price List and Operations Manual are references to those documents under the same Service Appendix as this Service Description. References to the Service Appendix are references to the Service Appendix for the Commercial Handover Connection Service.

2. Commercial Handover Connection Service

- 2.1. The Commercial Handover Connection Service (and its associated functions, including the associated functions of Chorus Systems):
 - 2.1.1. is a linking service that provides the inter-network connectivity between Compatible Services and the Service Provider's Network;
 - 2.1.2. provides the management function and physical connectivity between the interface port on the Chorus aggregation switch device (where access tail services are aggregated and presented for handover) and the MOFDF in the Chorus Site where the Handover Point is located; and
 - 2.1.3. provides the Bitstream ENNI functions at the Handover Point.
- 2.2. The Diagram set out in Appendix A illustrates the Commercial Handover Connection Service. The technical specification of the Commercial Handover Connection Service is set out in Appendix B. The Commercial Handover Connection Service is provided between the Demarcation Points.
- 2.3. The Commercial Handover Connection Service is an input service which a Service Provider can combine with the Compatible Services, the Service Provider's own network or wholesale services provided by other providers to provide telecommunications services to End Users.
- 2.4. The Commercial Handover Connection Service includes:
 - 2.4.1. the Handover Point interface port on the Chorus network aggregation switch device;
 - 2.4.2. the Tie Cable between the aggregation switch interface and the MOFDF; and
 - 2.4.3. the fibre connector (position) on the MOFDF.

3. **Commercial Handover Connection Service and implementation activities**

Installation Services

- 3.1. The Commercial Handover Connection Service includes a standard install (in each case to the extent that the relevant provisioning works are not already complete for the relevant Order). A standard install for the Commercial Handover Connection Service includes:
- 3.1.1. a physical port at the Handover Point; and
 - 3.1.2. one or more fibre cables from the physical port to the Handover Point MOFDF.

Core Commercial Handover Connection Service

- 3.2. The Commercial Handover Connection Service interface details are listed in Appendix B - the Technical Specification.

4. **Service Provider Connection**

- 4.1. The Service Provider will require an optical fibre access from the Chorus MOFDF to the Service Provider's Network.
- 4.2. The options to connect to the Service Provider's Network are:
- 4.2.1. Connection to Service Provider or Other Service Provider co-location space within the relevant Chorus Site using the Tie Cable service supplied under the relevant co-location service;
 - 4.2.2. Connection to a site outside the relevant Chorus Site within the Service Provider's Network using DFAS or a combination of DFAS and ICABs; or
 - 4.2.3. Service Provider or third party fibre – with this option the Service Provider utilises their own optical fibre access or that of a third party fibre provider for the linking component from the Service Provider's Network point of presence (**POP**) to the Chorus MOFDF,

(each a **Service Provider's Network Connection**).
- 4.3. Connection details are provided in the Operations Manual.
- 4.4. Any Tie Cable, co-location service, DFAS, ICABs, Service Provider or third party fibre is not part of the Commercial Handover Connection Service and additional terms and charges will apply where the Service Provider takes such Services from Chorus or a third party.

5. Demarcation Points

Compatible Services Demarcation Point

- 5.1. The Compatible Services Handover Demarcation Point is the point where the aggregated instances of the Compatible Service within the applicable Coverage Area are handed over at the Handover Point.

Service Provider's Network Connection Demarcation

- 5.2. The Service Provider's Network Connection Demarcation Point is the point where the Commercial Handover Connection Service is handed over to the Service Provider's Network as contemplated by clause 4.2

6. Geographic Availability

- 6.1. A Service Provider can request the Commercial Handover Connection Service at any of Chorus' Handover Points for the required Compatible Services.
- 6.2. The Chorus Sites at which Handover Points for each Chorus Compatible Service can be established are listed in the relevant Service Provider Guide.
- 6.3. The traffic passed over the Commercial Handover Connection Service will be governed by the terms pertaining to the Compatible Service or backhaul service being handed over at the Handover Point.
- 6.4. For the Commercial Handover Connection Service, the distance between Chorus and Service Provider equipment is limited to a 5km radius from the Handover Point. The Service Provider's equipment must be at a location where Chorus would normally provide a commercial data service equivalent to the Commercial Handover Connection Service interface type (i.e. not on an offshore island or promontory).

7. Commercial Handover Connection Service Availability

- 7.1. A Commercial Handover Connection Service is deemed unavailable when no data can pass between the Handover Point and the Service Provider facing service Demarcation Point associated at the Chorus OFDF or the Chorus supplied Handover Fibre OFDF (Chorus OFDF at the Service Provider POP) during Agreed Service Hours, unless the outage was a planned outage, a force majeure event, or a failure arising on the Service Provider side of the Handover Link.

| Commercial Handover Connection Service Availability | |
|---|--------|
| Value | 99.95% |

* Availability figure based on 7x7x7 service hours over a year (7am -7pm per day over 365 days).

Appendix A - Diagrams of the Commercial Handover Connection Service (CSA)

The following diagram provides a simplified overview of the physical components of Commercial Handover Connection Service.

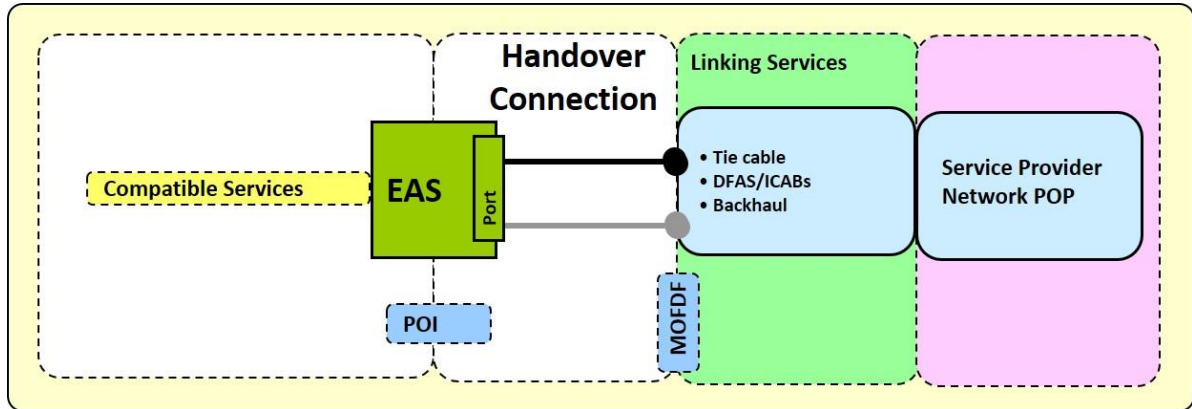

Appendix B – Technical Specification of the Commercial Handover Connection Service (CSA)

Commercial Handover Connection Physical Interface

| | 1Gb Service Option | | 10Gb Service Option | |
|-----------------------|--|---|---|------------------------------------|
| Connector Type | Fibre terminations must be SC/APC type connectors (complying with the IEC 61754-4 standard) or alternatively LC/APC type connectors (complying with the IEC 61754-20 standard) as appropriate. | | | |
| Fibre Type | External fibre must comply with ITU-T specification G.652. Internal building fibres may comply with ITU-T G.657A. | | | |
| Standard | Laser types and path characteristics expected to be designed to a minimum standard which are contained in the documents IEEE 802.3 Section 5 standard. | | | |
| Testing | Testing for power loss will be at either 1310 or 1550 nm 1625 nm reserved for non disruptive testing | | | |
| Interface Protocol | Gigabit Ethernet | | 10 Gigabit Ethernet | |
| MTU (bytes) | 9100 | | 9100 | |
| Bandwidth | GigE: A capacity of 1000 Mbps for Layer 1 transmission. | | GigE: A capacity of 9.953 Gbit/s (WAN-PHY) / 10.3125 Gbit/s (LAN-PHY) for Layer 1 transmission. | |
| Optical Parameters | Single Fibre Working | Dual Fibre Working | Internal Exchange termination: | External Exchange termination: |
| Average Receive Power | -18.7 dBm (minimum) -3.0 dBm (Maximum) | -18.8 dBm (minimum) +0.7 dBm (maximum) | -10.3 dBm (min) 0.5 dBm (max) | -11.3 dBm (min) -1.0 dBm (max) |
| Centre wavelength | TX 1310nm RX 1490nm 1000BASE-BX-u (1 GigE) | 1310 nm 1000BASE-LX | 1310 nm 10GBASE-LW/LR (10 GigE) | 1550 nm 10GBASE-EW/ER (10 GigE) |

| | | | | |
|----------------------------|--|--|---------------------------------------|-------------------------------------|
| Coupled Transmit Power | -9.0 dBm (minimum) -3.0 dBm (Maximum) | -8.2 dBm (minimum) -3.7 dBm (maximum) | -8.2 dBm (min) 0.5 dBm (max) | -4.7 dBm (min) 4.0 dBm (max) |
| Layer 2 Parameters | | | | |
| Terminating VLAN Tag Range | Service Specific – assigned by Chorus | | Service Specific – assigned by Chorus | |
| Maximum VLAN Tags | Service Specific – assigned by Chorus | | Service Specific – assigned by Chorus | |

Commercial Handover Connection Interface

- Encapsulation is 802.1ad. Alternative Encapsulation option is NULL.
- Service VLAN Ethertype is 88a8. Alternative Ethertype options are 8100, 9100, 9200.
- SVIDs will be allocated in the range 2 to 4094 (inclusive)
- See individual service descriptions for how SVID and CVIDs are assigned.